



Installation Guide



55015

Kargo Master Safari
Rancho Cordova, CA 95742
800-343-7486
customerservice@kmsafari.com

***PLEASE READ ALL INSTRUCTIONS AND WARNINGS PRIOR TO ASSEMBLING,
INSTALLING AND USING THIS PRODUCT***

Warning



Always check for wires, fuel tanks and lines, brake lines and other important vehicle functionality items prior to drilling and installing all products.

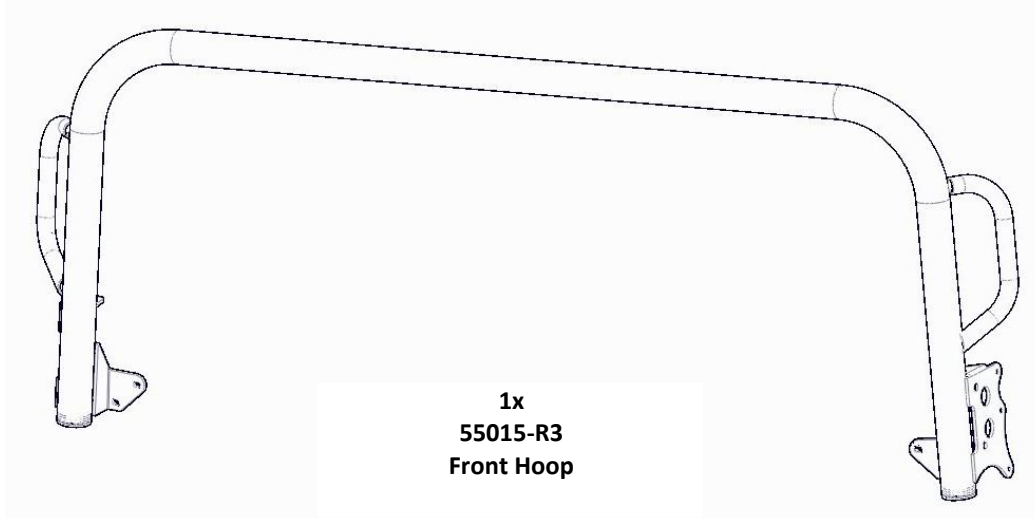
Tools Needed

- 5mm Allen Hex
-

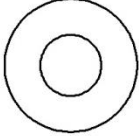
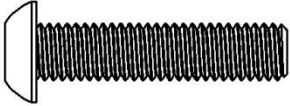

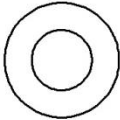
Table of Contents

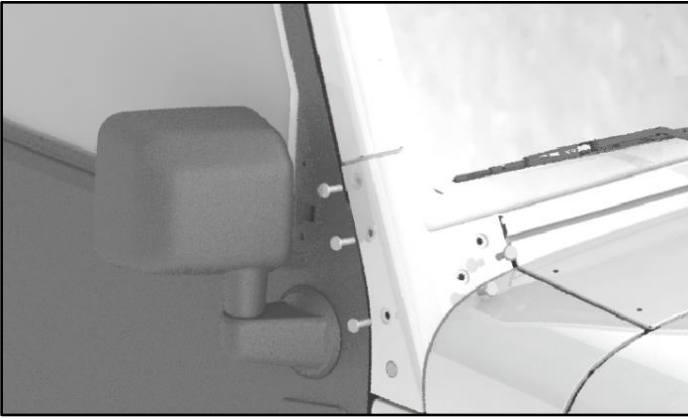
Parts List	3
Hardware List	3
Step 1 Factory TORX Removal	4
Step 2 Tube Cap	4
Step 3 Front Hoop Installation	5
Step 4 Replace TORX	5

Before You Begin



HARDWARE (to scale)

	PART NUMBER	DESCRIPTION	QTY.
	55015-00-001	Washer - Nylon 6 - Natural - .33" ID x .08"	10
	91239A438	M8 x 35mm Button Head Cap Screw	10
	91190A550	M8 High Collar Split Lock Washer / Smaller OD	10
	91455A440	M8 Flat Washer	10

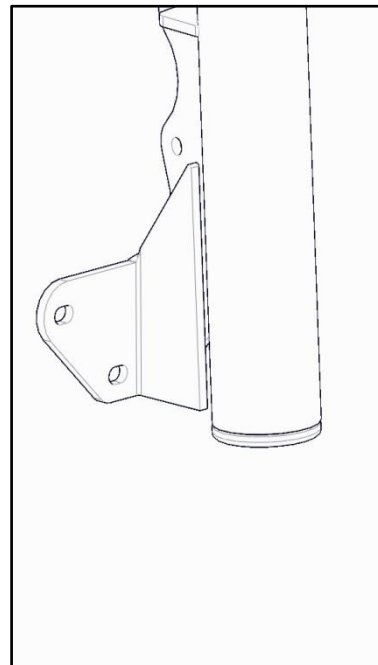
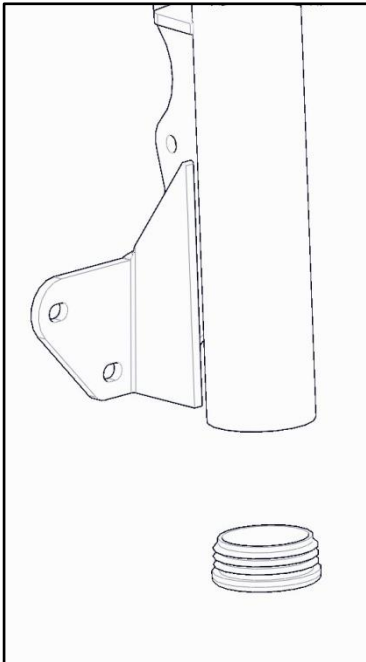


Step 1

- Remove 5 TORX bolts from both A-Pillars of Jeep using a T40 drive. Remove only the top 3 bolts on the side panel.

Step 2

- Insert tube cap into bottom of tube.

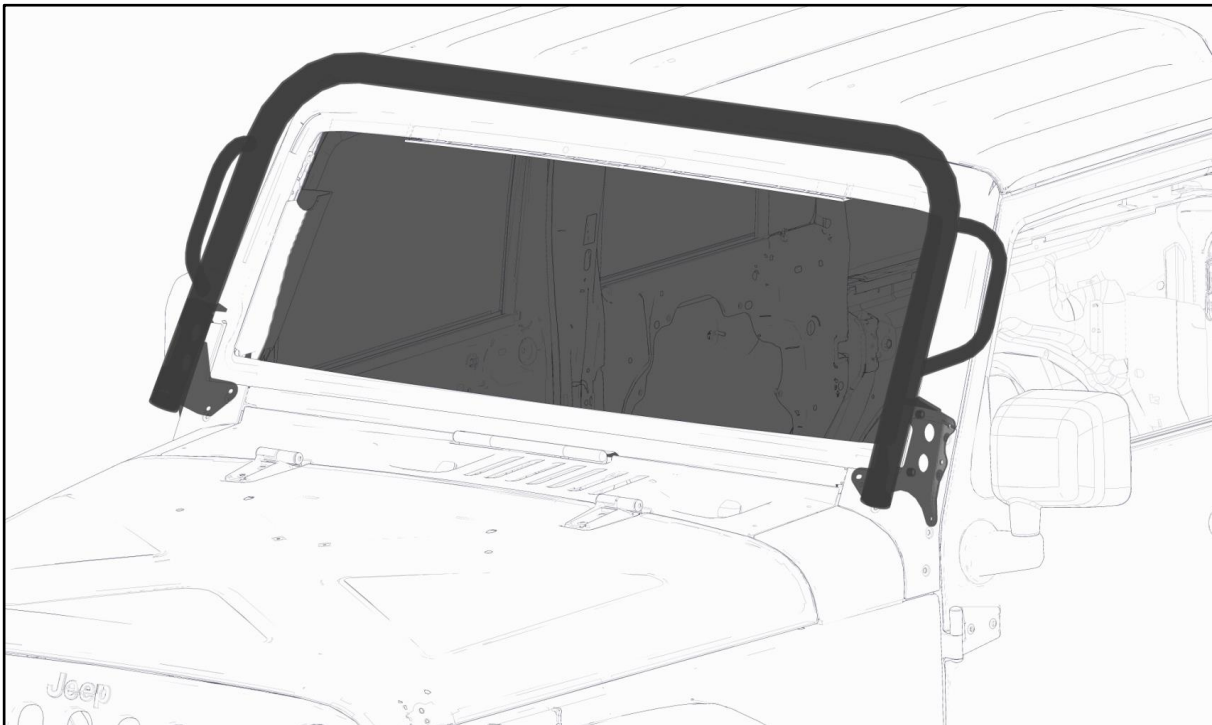


Step 3

- After removing all 10 bolts, install 55015. The front hoop will line up with the holes from bolts previously removed.
- In between the front hoop and the body of the JEEP, be sure to insert Nylon washer. Bolt in place using previously removed factory TORX bolts.

DO NOT TIGHTEN ANY BOLTS UNTIL ALL 10 BOLTS ARE INSTALLED

**** If issues arise with aligning the front hoop to factory locations, We recommend to snug either the side or front bolts first, This allows the other holes to line up where previously mis-aligned. ****



Step 4

- Go back and replace all factory TORX bolts with button heads that are provided.
- Be sure all bolts are tight

Your installation is now complete