



PRODUCT: JL 392 Rack System, MetalCloak Bumper

REV: B | 09-25-2023 | R74040

READ INSTRUCTIONS IN FULL BEFORE INSTALLATION.

QUESTIONS? CALL 916-760-4575 M-F 7:00 AM – 5:00 PM PST

The ARS experience includes the ease of installation of our products. We design for most contingencies, but installation may be different based on different Jeep condition, configuration and/or year.

We are continually trying to improve our products and instructions – please help us by providing feedback and pictures if you find any part of the instructions that do not match your Jeep or are not easily understandable.

If you have any difficulties at all, please give us a call. Thank you and enjoy your ARS Products!

IMPORTANT NOTE: We use Stainless Steel Hardware where possible unless otherwise indicated. Therefore, a tube of Silver Anti-seize is provided and should be used on all bolts—only a small amount is needed.

WARRANTY INFORMATION: This article is sold without warranty expressed or implied. No warranty or representation is made as to this products ability to protect the user from injury or death. The user assumes that risk. The effectiveness, warranty and longevity of this equipment are directly related to the way it is INSTALLED, USED and/or MAINTAINED. THE USER ASSUMES ALL RISK. By purchasing this product and opening the packaging, purchasers expressly acknowledge, understand and agree that they take, select and purchase these ARS products from Armored Works, LLC, its affiliates and distributors and agents as is and with all faults. The entire risk as to the quality and performance of these ARS products is with the purchaser. Working on your vehicle can be a dangerous activity. If you are unsure of what you are doing, please leave mechanical or safety critical work to a skilled mechanic. We take no responsibility for the incorrect use and/or installation of ARS products.

Section 1: Tools & Notes on Installation



Tools Required: This list is the recommended tools for ease of installation. Other versions of the same tool can be used. For example, Allen Wrenches instead of Allen Drive Sockets.



Socket Wrench

5mm Allen 7/32" Allen
3/8" Allen 5/16" Allen
1/4" Allen



T40 Torx Socket

1/2" Socket 9/16" Socket
3/4" Socket 9/16" Wrench
1/2" Wrench 11/16" Wrench



13/32" Bit 17/32" Bit
5/16 Bit 3/8" Bit

Dremel & Cut-Off Wheel

Cutters



Blue Lock Tight

Clamps



HOW TO USE THIS GUIDE: The installation guide contains ALL steps for installation. Please read and follow the instructions in order of each page top to bottom and left to right.

Jeep Model: Instructions may apply to multiple Jeep models but are labeled separately where appropriate (i.e. TJ vs. LJ).

Options: Because of the number of component options we offer, these instructions may contain steps that will not match your configuration. You can skip these steps.

Images: Pictures are provided, and parts are labeled throughout the instructions. Each text box contains guidance based on the pictures next to it. The text will refer to alphabetical labels (A, B, etc.) found in the images.

Installation Notes: Terms may be used in the body of the instructions that you may not be familiar with, if you have any questions feel free to contact us at the number below, or email techhelp@metalcloak.com

QUESTIONS: Any questions or comments about the instructions? Call us at 916-760-4575 M-F 7:00 AM – 5:00 PM PST.

Section 2: Product Components



SHEET 1 OF 1

DC-0001 Rev B

ITEM	PART NUMBER/DESCRIPTION	QTY.
1	R75000 PRO FRONT HOOP WITH HANDLES, JL	1
2	R75020 4DR ROOF TRUSSES, JL	1
3	R75040 PRO REAR HOOP, JL	1
4	R75701 FRONT COWL MOUNTING BRACKETS, 392 MOJAVE	1

OPTIONS:

- R75060 REAR FRAME MOUNT METAL BUMPER, JL
- R75070 REAR FRAME MOUNT METALCLOAK BUMPER, JL
- R75075 METALCLOAK REAR BUMPER BRACKET COMBO, JL
- R75080 KAT WALK, JL

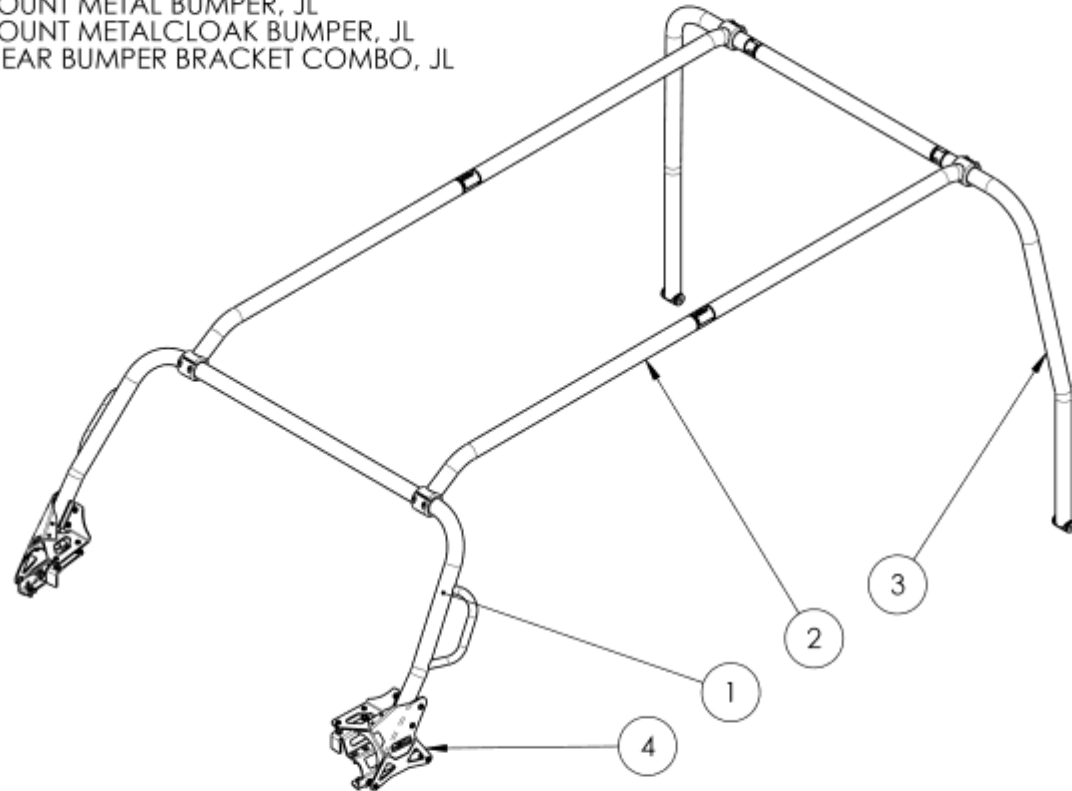

THE INFORMATION CONTAINED ON THIS DRAWING IS THE EXCLUSIVE PROPERTY OF ARMORED WORKS, LLC. UNAUTHORIZED REPRODUCTION IS PROHIBITED.

DO NOT SCALE DRAWING

Metal Cloak
A DIVISION OF ARMORED WORKS, LLC

PART NUMBER/DESCRIPTION

R74040 392 ROCKLANDER RACK SYSTEM, JL

Section 2: Product Components



DC-0001 REV A

SHEET 1 OF 1

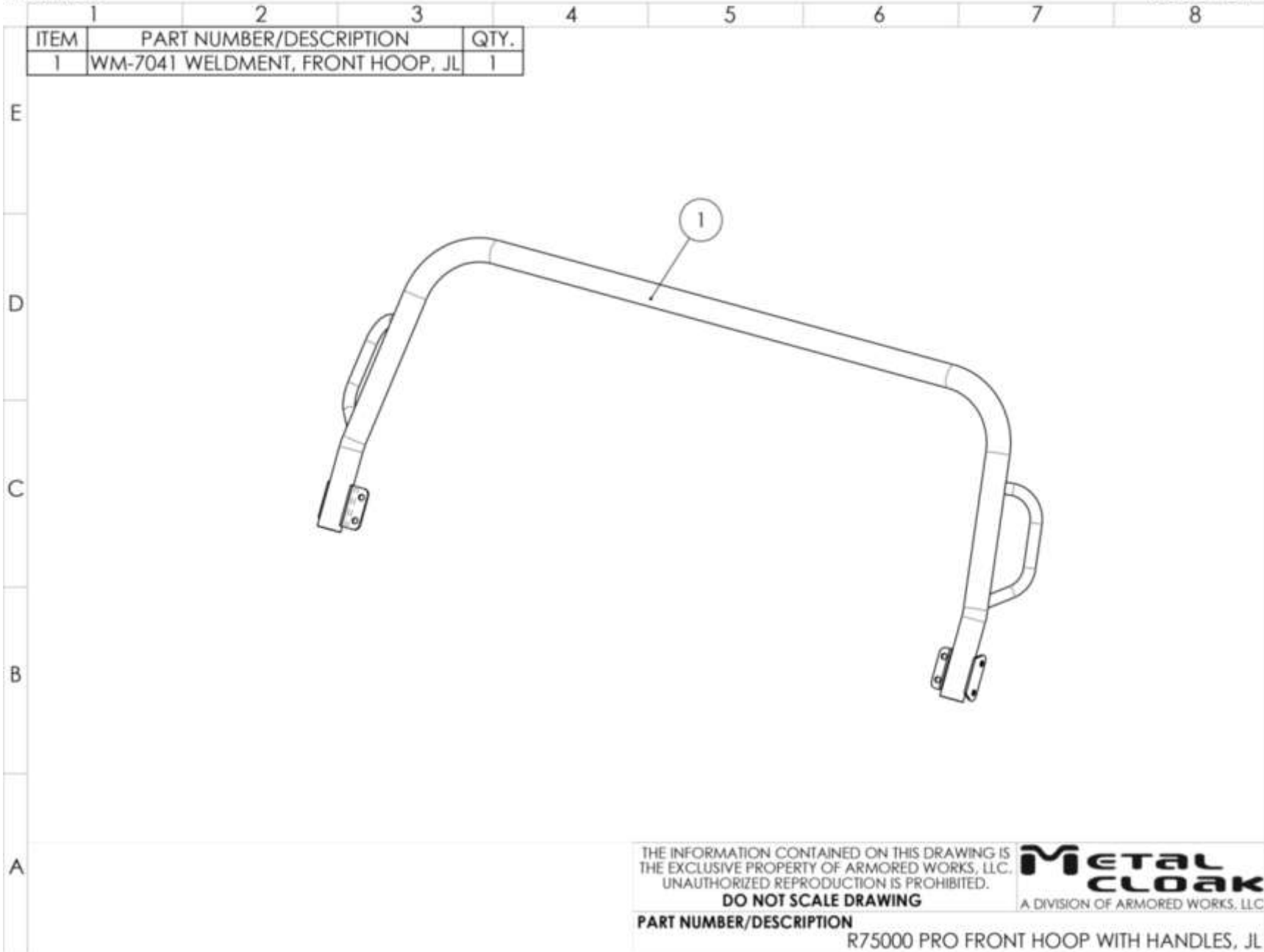

Section 2: Product Components



SHEET 1 OF 2

DC-0001 REV A

ITEM	PART NUMBER/DESCRIPTION	QTY.
1	CS-0216 PLT, ARS LOGO TAG PLT	2
2	FA-2116 BLIND POP RIVET 0.125 X 0.25L SS	4
3	WM-7044 WELDMENT, FRONT INNER BASE SUPPORT LOWER, JL	1
4	WM-7044-P WELDMENT, FRONT INNER BASE SUPPORT LOWER, JL	1
5	WM-7099 WELDMENT, 392-MOJAVE COWL MOUNT, JL-JT	1
6	WM-7099-P WELDMENT, 392-MOJAVE COWL MOUNT, JL-JT	1
7	WM-7100 WELDMENT, 392-MOJAVE UPPER PIER PLT, JL-JT	1
8	WM-7100-P WELDMENT, 392-MOJAVE UPPER PIER PLT, JL-JT	1
HK-R75701		
9	B9999 INSTALLATION TOOL, 0.38-16 RIVET NUT	1
10	CS-0158 BILLET, FRONT INNER SPACER, JL	4
11	CS-0170 BILLET, FRONT HOOP BASE OUTER SPACER, JL	4
12	FA-2020 CLAMP, 0.188X1.375 VINYL LOOP, ZINC	1
13	FA-2107 LOCTITE 243, BLUE .02OZ CAPSULE	1
14	FM-08269 WASHER, 8.4ID X 15.0OD X 1.6TH SS 18-8 PLAIN	8
15	FM-08278 SBHCS, M8-1.25 X 35L SS 18-8 PLAIN	8
16	FS-05047 NYLOCK NUT, 0.31-18 X 0.34H STL GF ZINC	6
17	FS-05194 HHCS, 0.31-18 X 1.25L STL G5 ZINC	6
18	FS-05242 WASHER, 0.33ID X 0.63OD X 0.05TH STL ZINC	18
19	FS-06001 SBHCS, 0.38-16 X 0.75L SS 18-8 PLAIN	4
20	FS-06010 SBHCSC, 0.38-16 X 1.0L SS 18-8 PLAIN	4
21	FS-06030 NYLOCK NUT, 0.38-16 X 0.45H STL GF ZINC	4
22	FS-06031 HHCS, 0.38-16 X 1.0L STL G5 ZINC	2
23	FS-06033 RIVET NUT, 0.38-16 X 0.15GRIP STL G5 GOLD ZINC	2
24	FS-06231 LOCK WASHER SPLIT, 0.39ID X 0.68OD X 0.10TH STL ZINC	2
25	SP-0105 ANTI-SEIZE TUBE	1

NOTES:
1) PACKAGING BOM/INSTRUCTIONS ON SHEET 2

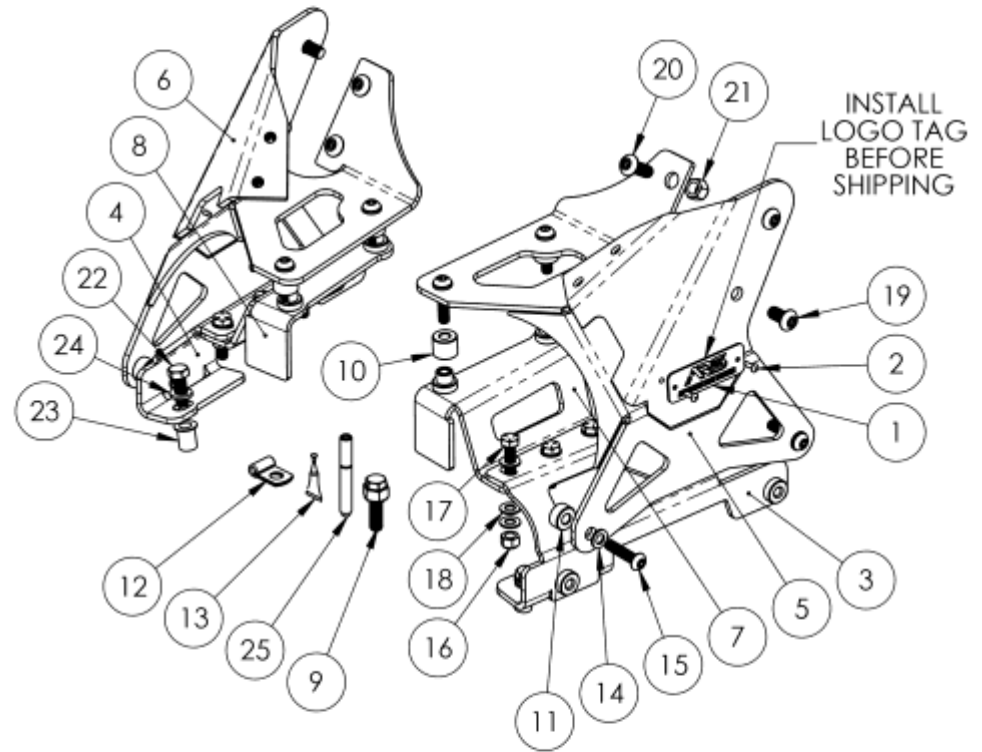

THE INFORMATION CONTAINED ON THIS DRAWING IS THE EXCLUSIVE PROPERTY OF ARMORED WORKS, LLC. UNAUTHORIZED REPRODUCTION IS PROHIBITED.
DO NOT SCALE DRAWING



PART NUMBER/DESCRIPTION
R75701 FRONT COWL MOUNTING BRACKETS, 392 MOJAVE

Section 2: Product Components



SHEET 1 OF 1

DC-0001 REV A

ITEM	PART NUMBER/DESCRIPTION	QTY.
1	WM-7049 WELDMENT, PRO 4DR SPREADER 2.00, JL	2
2	CS-0039 BILLET, PRO SPREADER BAR END CAP	4
3	FS-05235 SHCS, 0.31-18 X 0.88L STL G8 ZINC	16

DETAIL A
SCALE 1 : 4

THE INFORMATION CONTAINED ON THIS DRAWING IS THE EXCLUSIVE PROPERTY OF ARMORED WORKS, LLC. UNAUTHORIZED REPRODUCTION IS PROHIBITED. DO NOT SCALE DRAWING

METAL CLOAK
A DIVISION OF ARMORED WORKS, LLC

PART NUMBER/DESCRIPTION: R75020 PRO 4DR SPREADER BARS, JL

Section 2: Product Components



SHEET 1 OF 2

DC-0001 REV A

ITEM	PART NUMBER/DESCRIPTION	QTY.
1	WM-7051 WELDMENT, PRO RACK REAR HOOP LEG, JL	1
2	WM-7051-P WELDMENT, PRO RACK REAR HOOP LEG, JL	1
3	WM-7052 WELDMENT, PRO RACK REAR HOOP UPPER TUBE, JL	1
4	FA-2002 BUSHING, .375ID X .50OD X 2.50L, STL ZINC	2
5	FA-2006 BUSHING, 0.50ID X 1.00 X 1.00 BLK URETHANE	4
6	FS-08236 SHCS, 0.5-13 X 1.5L STL G8 ZINC	2
7	FS-08237 NYLOCK NUT, 0.5-13 X 0.59H STL GF ZINC	2

THE INFORMATION CONTAINED ON THIS DRAWING IS THE EXCLUSIVE PROPERTY OF ARMORED WORKS, LLC. UNAUTHORIZED REPRODUCTION IS PROHIBITED.
DO NOT SCALE DRAWING

PART NUMBER/DESCRIPTION	QTY.
R75040 PRO REAR HOOP, JL	1

Section 2: Product Components



DC-0001 REV A

SHEET 1 OF 1

ITEM	PART NUMBER/DESCRIPTION	QTY.
1	CS-0184 PLT, REAR HOOP MOUNT METALCLOAK, JL	2
2	FS-05046 WASHER, 0.34ID X 0.75OD X 0.04TH SS 18-8	4
3	FS-05047 NYLOCK NUT, 0.31-18 X 0.34H STL GF ZINC	4
4	FS-05248 CARRIAGE BOLT, 0.31-18 X 1.0L STL G5 ZNC	4
5	FS-06004 WASHER, 0.41ID X 0.81OD X 0.05TH SS 18-8	2
6	FS-06227 HHCS, 0.38-16 X 3.5L STL G5 ZINC	2
7	FS-06231 LOCK WASHER SPLIT, 0.39ID X 0.68OD X 0.10TH STL ZINC	2

THE INFORMATION CONTAINED ON THIS DRAWING IS THE EXCLUSIVE PROPERTY OF ARMORED WORKS, LLC. UNAUTHORIZED REPRODUCTION IS PROHIBITED.
DO NOT SCALE DRAWING

Metal Cloak
 A DIVISION OF ARMORED WORKS, LLC

PART NUMBER/DESCRIPTION
 R75070 REAR FRAME MOUNT METALCLOAK BUMPER, JL

Section 3: Installation Instructions



Step 1: Front Hoop Bracket Installation

- A. Remove antenna.
- B. Using a T40 torx wrench remove the four stock torx bolts from the side panel and hood cowl.
- C. Remove the cowl cover.
- D. Using cutters remove the plastic tab underneath the hood cowl.
- E. Mask area around holes and use a dremel enlarge the T40 torx holes on the hood cowl making sure they are large enough to fit the upper bracket's 1/2" standoffs. Do NOT use a drill to open the holes.

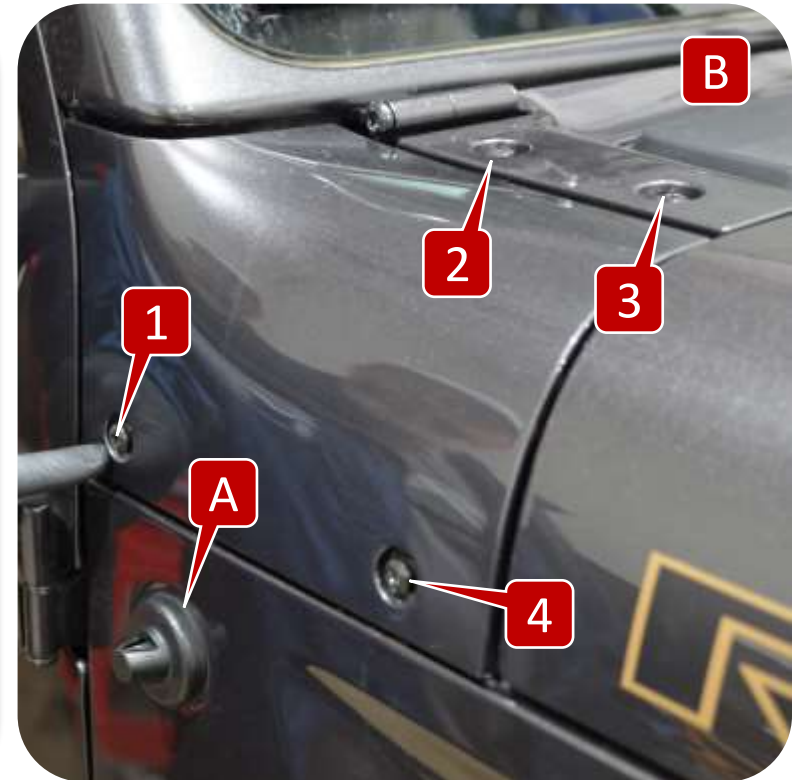

Section 3: Installation Instructions



Step 1: Front Hoop Bracket Installation

- F. Enlarge the two outer flange stock bolt holes to 13/32".
- G. Re-install both parts of the pier plates temporarily and hold in place with 2 of the stainless- steel allen-head bolts
- H. Mark the (3) upper bracket holes and the (1) lower rivet nut hole for drilling
- I. Remove stainless bolts and both parts of the pier plate (*upper and side bracket*).

Note: *The side bracket bolt hole that requires drilling on the passenger side should align with a pre-existing hole that will need to be expanded to 17/32".*

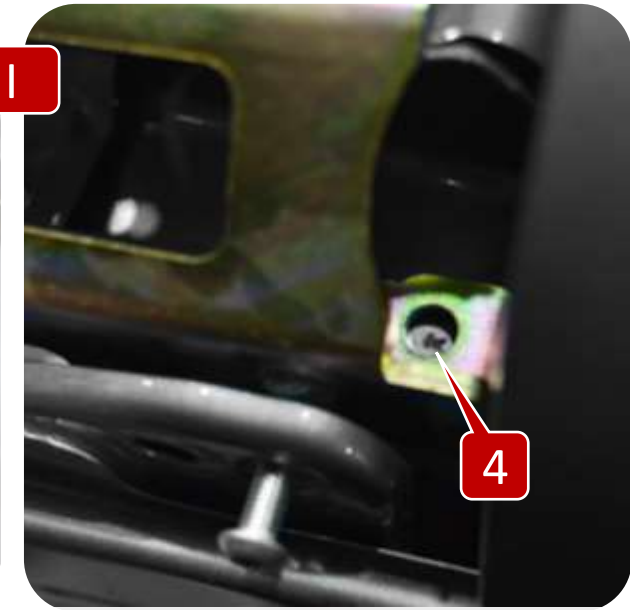
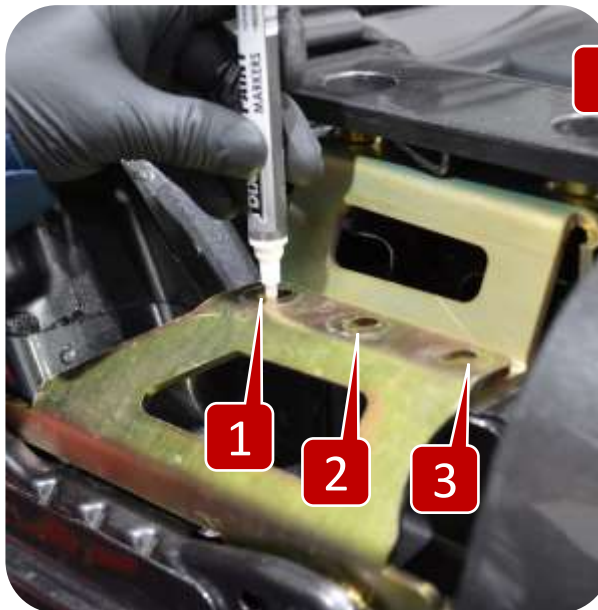

Section 3: Installation Instructions



Step 1: Front Hoop Bracket Installation

- J. Center punch and drill a pilot hole on the three upper bracket marked locations and step up to a 5/16" drill bit.
- K. Center punch and drill a pilot hole on the one side bracket marked location and step up to a 17/32" drill bit. We recommend opening the hood to gain better access to the marked location.
- L. Paint any exposed metal to prevent rusting.
- M. Using the provided installation tool install the rivet nut into the 17/32" hole. Use a 9/16" socket and 11/16" wrench for the installation tool.



Note: *The passenger side has two layers of steel that must be drilled through.*

Section 3: Installation Instructions



Step 1: Front Hoop Bracket Installation

N. Using a clamp hold the side panel securely to help prevent movement when cutting.

Note: *The marked locations are the parts that will need to be removed from the side panel.*

Front

Note

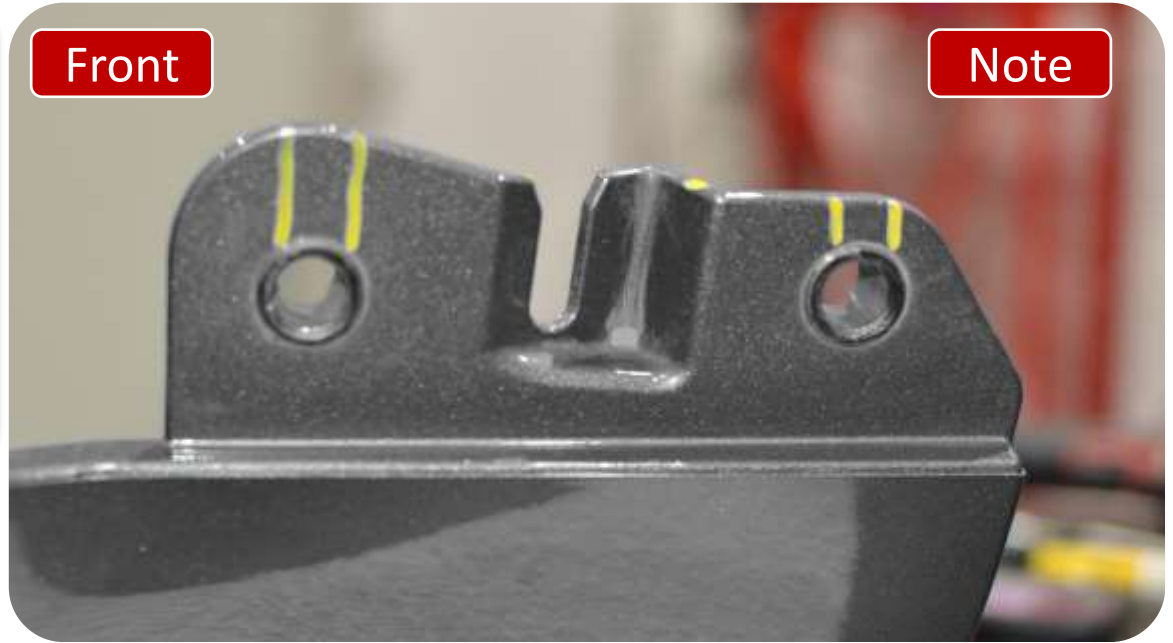

Back

Note

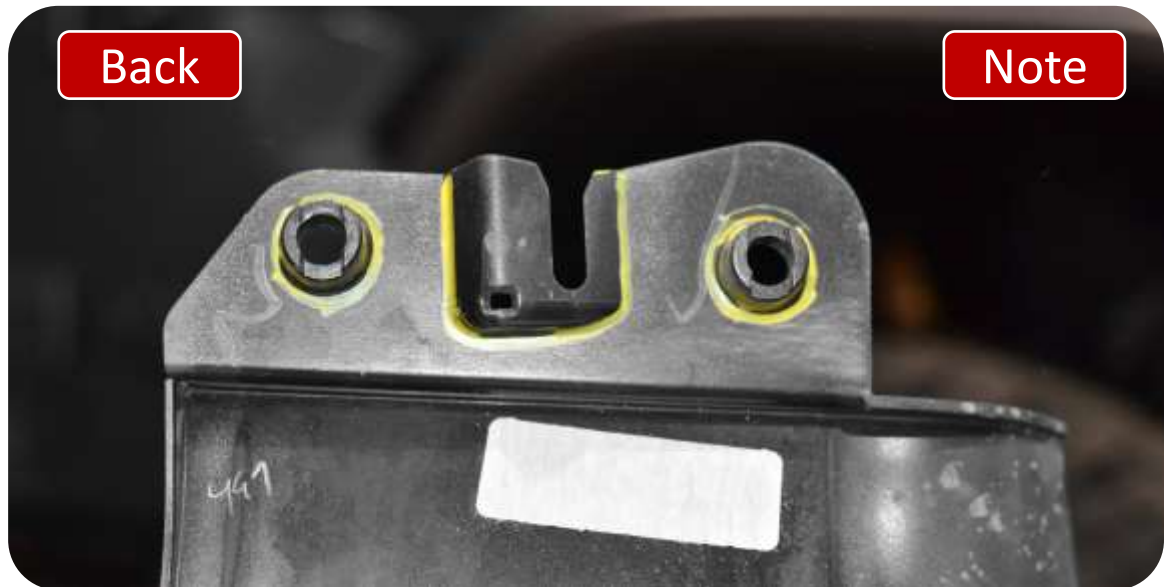

Section 3: Installation Instructions



Step 1: Front Hoop Bracket Installation

- O. Using the cut off wheel cut the notches on the front of the plastic side panel. The notches need to be wide enough to fit snugly around the bracket standoffs (approx. 1/2" Wide). If cuts are too wide the panel can rattle against the bracket.
- P. Using a cut off wheel cut off the plastic standoffs on the back of the side panel.
- Q. Using a cut off wheel cut off the previously marked center bracket.

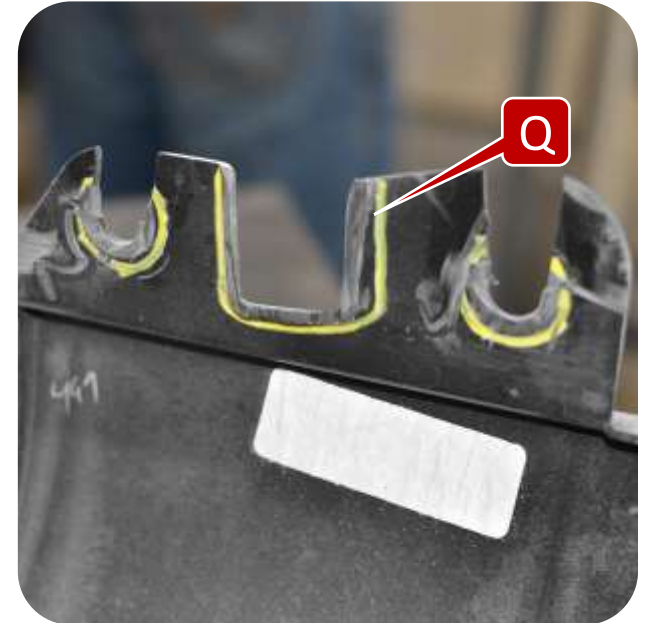
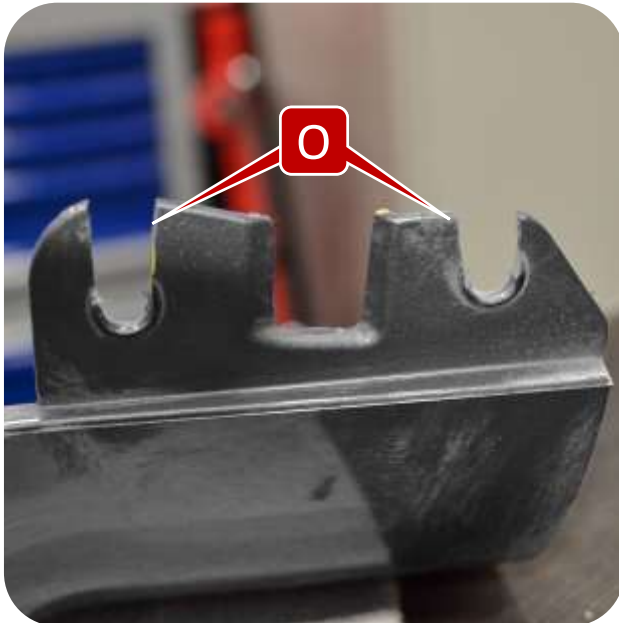

Section 3: Installation Instructions



Step 1: Front Hoop Bracket Installation

- R. Install the upper and side brackets. The side bracket sits on top of the upper bracket.
- S. Place a spacer washer between each of the three holes of the two brackets.
- T. Loosely install the provided bolts, washers and nuts into the three bolt holes. *(There are nine total washers: one washer on top, one as a spacer, one on the bottom).*
- U. Install two of the provided allen bolts into the drilled-out stock locations to hold the side bracket into place before tightening the hex head bolts.

Note: MetalCloak recommends placing a shop towel over the cowl area before installing the brackets to make sure the hardware does not fall.

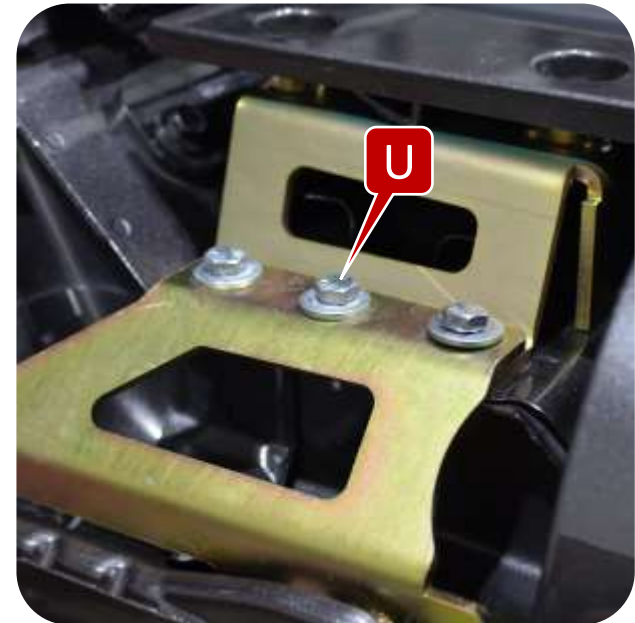

Section 3: Installation Instructions



Step 1: Front Hoop Bracket Installation

- V. Install the provided bolt and split washer into the rivet nut.
- W. Using a 1/2" socket and wrench tighten the three bracket bolts.
- X. Using a 9/16" socket tighten the rivet nut bolt.
- Y. If the allen head bolts do not move freely you must unbolt and readjust the bracket. Once the allen head bolts move freely remove the two bolts and reinstall the plastic hood cowl.

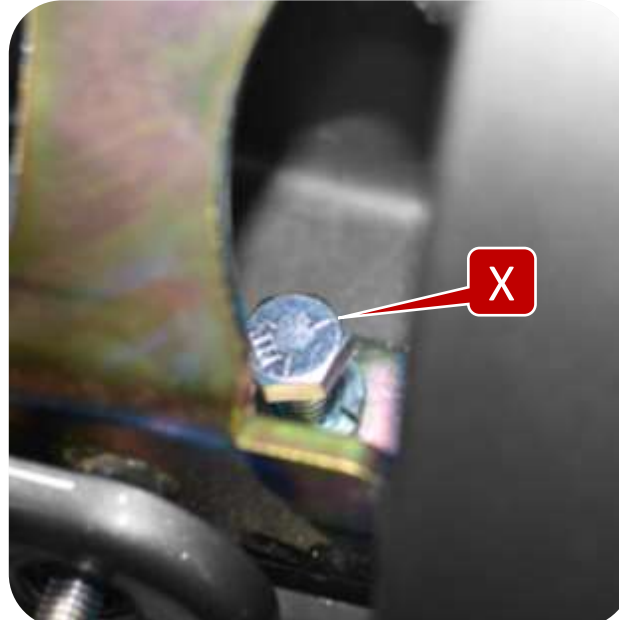
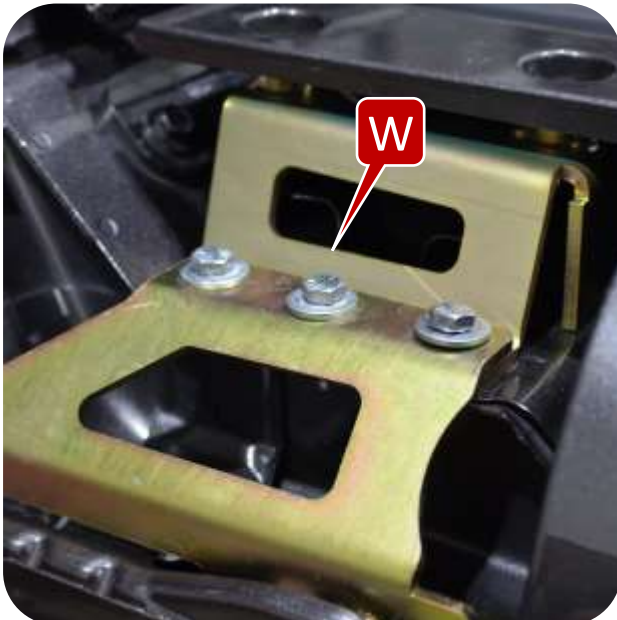
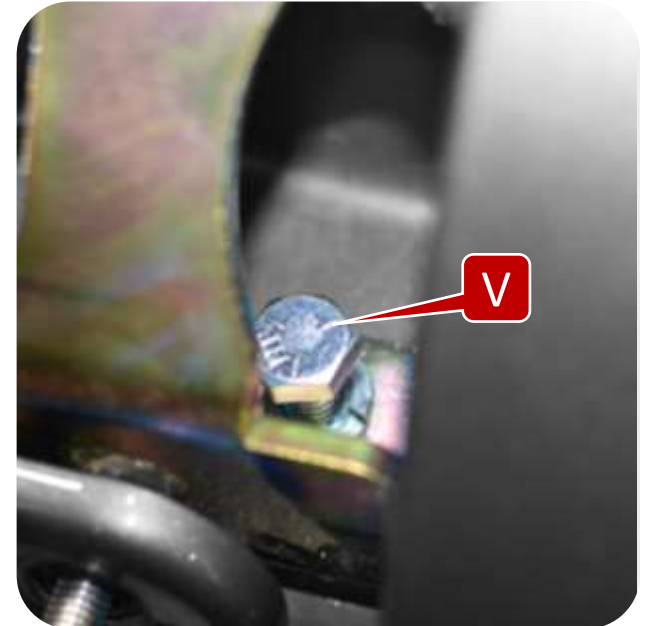

Section 3: Installation Instructions

Step 2: Front Hoop Mounting Base Installation

Note: ARS highly recommends using blue lock tight on the four allen head bolts when installing the front hoop mounting base.

- Z. Place the larger provided spacers into the top T40 bolt locations.
- AA. Loosely install the hoop mounting base into the top spacers using the provided longer allen bolts and washers. Do not fully tighten.
- BB. Place the provided smaller spacers into the stock T40 bolt locations.
- CC. Loosely install the mounting base into the side spacers using the provided longer allen bolts and washers. Do not fully tighten.



Section 3: Installation Instructions



Step 3: Front Hoop Installation

- DD. Install the finishing caps into the front hoop.
- EE. Using the provided allen head bolts (use anti-seize) attach the hoop to the mounting brackets.
- FF. On the passenger side insert the antenna into the provided antenna clamp and secure to the mounting bracket using the provided hoop allen bolt. Tighten with a 7/32" allen wrench.
- GG. Using a 5mm allen wrench tighten the 4 allen bolts. Repeat on other side.



Note: ARS recommends having a second pair of hands help install the front hoop.

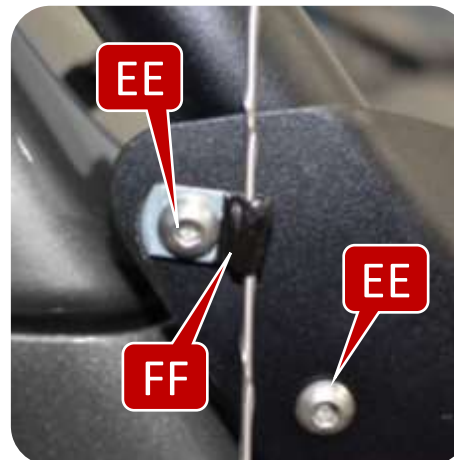
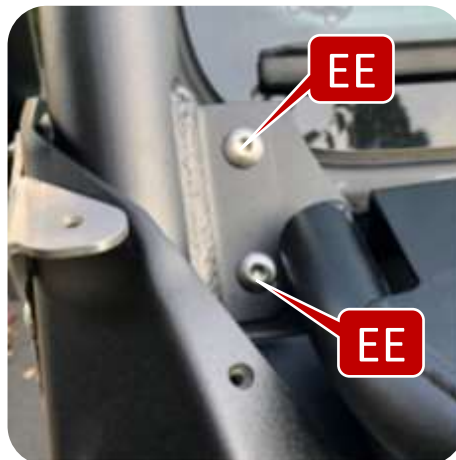

Section 3: Installation Instructions

Step 4: Rear Hoop Preparation

HH. Install the bushing ends into the end of the rear hoop.

II. Install the bushing sleeve into the rear hoop bushing ends.

JJ. Using a 3/8" allen socket or wrench install the cross bar to the hoop ends.



Section 3: Installation Instructions



Step 4: Rear Hoop Preparation

- KK. Place the spreader bars with the engineered bend facing the front hoop.
- LL. Install the spreader bar clamp ends to the front hoop using the provided allen head bolts. **DO NOT FULLY TIGHTEN.**
- MM. ARS recommends having a second person help install the spreader bar clamps to the rear hoop using the provided allen head bolts. **DO NOT FULLY TIGHTEN.**



Section 3: Installation Instructions



Step 4: Rear Hoop Preparation

Note: When installing the rear hoop make sure the rear hoop is evenly spaced from the Jeep tub, use a square to make sure the rear hoop is straight vertically, and make sure there is clearance for the gas cap to open and close.

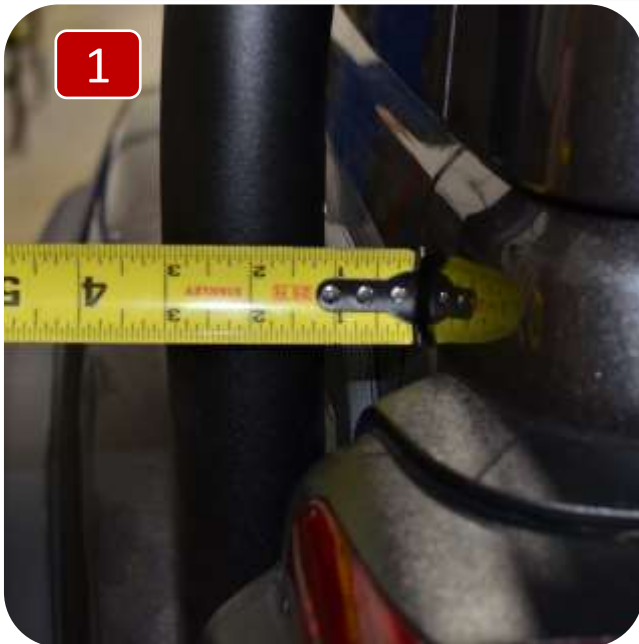

Section 3: Installation Instructions



Step 5: Rear Hoop Mounting Brackets (MetalCloak Bumper)

- NN. Once the rear hoop has been aligned mark the rear hoop foot holes for preparation for drilling.
- OO. Using a 9/16" socket remove the rear hoop mounting brackets from the hoop.
- PP. Using a 5/16" allen wrench remove the bumper end cap allen head bolts.
- QQ. Using a 3/4" socket remove the two hex head bolts on the underside of the bumper end caps.



Section 3: Installation Instructions



Step 5: Rear Hoop Mounting Brackets (*MetalCloak Bumper*)

RR. Drill the marked locations on the end caps to 3/8". ARS recommends drilling a pilot hole first and working your way up to a 3/8" drill bit.

SS. Paint any exposed metal to help prevent rust.

TT. Using the provided carriage bolts and nuts install the rear hoop mounting brackets making sure the pem on the bracket faces inward.

UU. Tighten the mounting brackets to the end caps using a 9/16" wrench.

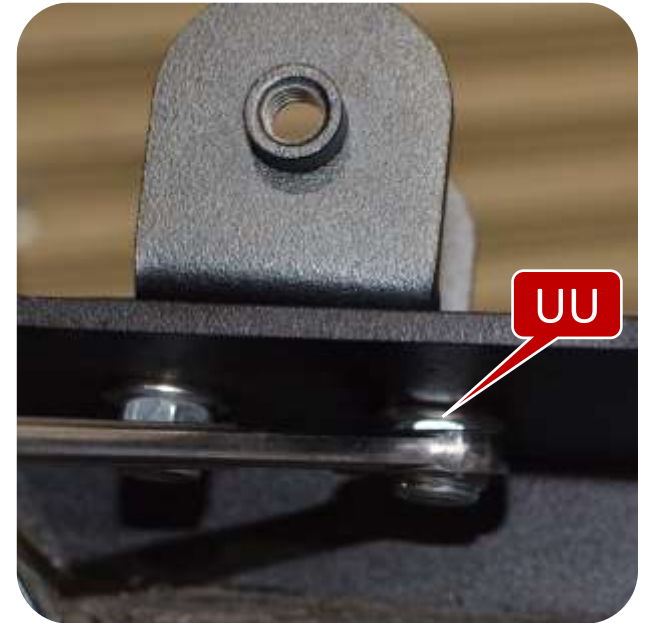

Section 3: Installation Instructions



Step 5: Rear Hoop Mounting Brackets (MetalCloak Bumper)

VV. Re-install the bumper end caps onto the rear bumper.

WW. Insert the rear hoop into the mounting bracket.

XX. Using a 5/16" allen wrench install the button head bolts.

YY. Using a 3/4" socket install the two hex head bolts on the underside of the bumper end caps.

ZZ. Using a 9/16" socket install the rear hoop into the mounting brackets.



Section 3: Installation Instructions



Step 6: Spreader Bar Installation

Note: ARS recommends using anti-seize on the spreader bar bolts.

AAA. Make sure the spreader bars are 40" on center.

BBB. Using a 1/4" allen wrench tighten the front spreader bar bolts. Torque to 24ftlbs.

CCC. Using a 1/4" allen wrench tighten the rear spreader bar bolts. Torque to 24ftlbs.

