



**PRODUCT: TJ/LJ Dual Function LED Marker & Blinker Light**

REV: C | 07-01-2015 | II-2209

**READ INSTRUCTIONS IN FULL BEFORE INSTALLATION.  
QUESTIONS? CALL 916-631-8071 M-F 7:00 AM – 5:00 PM PST**

The MetalCloak experience includes the ease of installation of our products. We design for most contingencies, but installation may be different based on different Jeep condition, configuration and/or year.

We are continually trying to improve our products and instructions – please help us by providing feedback and pictures if you find any part of the instructions that do not match your particular Jeep or are not easily understandable.

If you have any difficulties at all, please give us a call. Thank you and enjoy your MetalCloak Products!

**IMPORTANT NOTE: We use Stainless Steel Hardware where possible. Therefore, a tube of Silver Anti-seize is provided and should be used on all bolts—only a small amount is needed.**

**WARRANTY INFORMATION:** This article is sold without warranty expressed or implied. No warranty or representation is made as to this products ability to protect the user from injury or death. The user assumes that risk. The effectiveness, warranty and longevity of this equipment are directly related to the manner in which it is INSTALLED, USED and/or MAINTAINED. THE USER ASSUMES ALL RISK. By purchasing this product and opening the packaging, purchasers expressly acknowledge, understand and agree that they take, select and purchase these MetalCloak products from Armored Works, LLC, its affiliates and distributors and agents as is and with all faults. The entire risk as to the quality and performance of these MetalCloak products is with the purchaser. Working on your vehicle can be a dangerous activity. If you are unsure of what you are doing, please leave mechanical or safety critical work to a skilled mechanic. We take no responsibility for the incorrect use and/or installation of MetalCloak products.

## Section: Tools & Notes on Installation



**Tools Required:** This list is the recommended tools for ease of installation. Other versions of the same tool can be used. For example, Allen Wrenches instead of Allen Drive Sockets.



Wire Cutter

Wire Stripper/Crimper



10MM Wrench

Electrical Tape  
or Shrink Wrap



Zip Ties (Optional)



**HOW TO USE THIS GUIDE:** The installation guide contains ALL steps for installation. Please read and follow the instructions in order of each page top to bottom, and left to right.

**Jeep Model:** Instructions may apply to multiple Jeep models, but are labeled separately where appropriate (i.e. TJ vs. LJ).

**Options:** Because of the number of component options we offer, these instructions may contain steps that will not match your particular configuration. You can skip these steps.

**Images:** Pictures are provided and parts are labeled throughout the instructions. Each text box contains guidance based on the pictures next to it. The text will refer to alphabetical labels (A, B, etc.) found in the images.

**Installation Notes:** Terms may be used in the body of the instructions that you may not be familiar with, if you have any questions feel free to contact us at the number below, or email [techhelp@metalcloak.com](mailto:techhelp@metalcloak.com)

**QUESTIONS:** Any questions or comments about the instructions? Call us at 916-631-8071 M-F 7:00 AM – 5:00 PM PST.

## Section 1: Tools & Notes on Installation



**Note:** Bought MetalCloak LED's? Then get the LED Replacement flasher for your TJ/LJ to return a regular rhythm to your signals.

*This Flasher is designed for all 2001 - 2006 TJ and TJ Unlimited.*

## Section 2: Product Components



ITEM	PART NUMBER/DESCRIPTION	QTY.
1	FA-1002 16-14GA BUTT SPLICE	4
2	FA-1003-R 16GA RED INSULATED COPPER WIRE	4
3	FA-1003-W 16GA WHITE INSULATED COPPER WIRE	2
4	FA-1004 22-16GA X 0.25IN RING TERMINAL	2
5	FA-1023 FEMALE BULLET CONNECTOR, D.18 X 16-14GA WIRE	6
6	FA-1029 0.75 LED MARKER-BLINKER LIGHT	2
7	FA-1030 MALE BULLET CONNECTOR, D.18 X 16-14GA WIRE	6

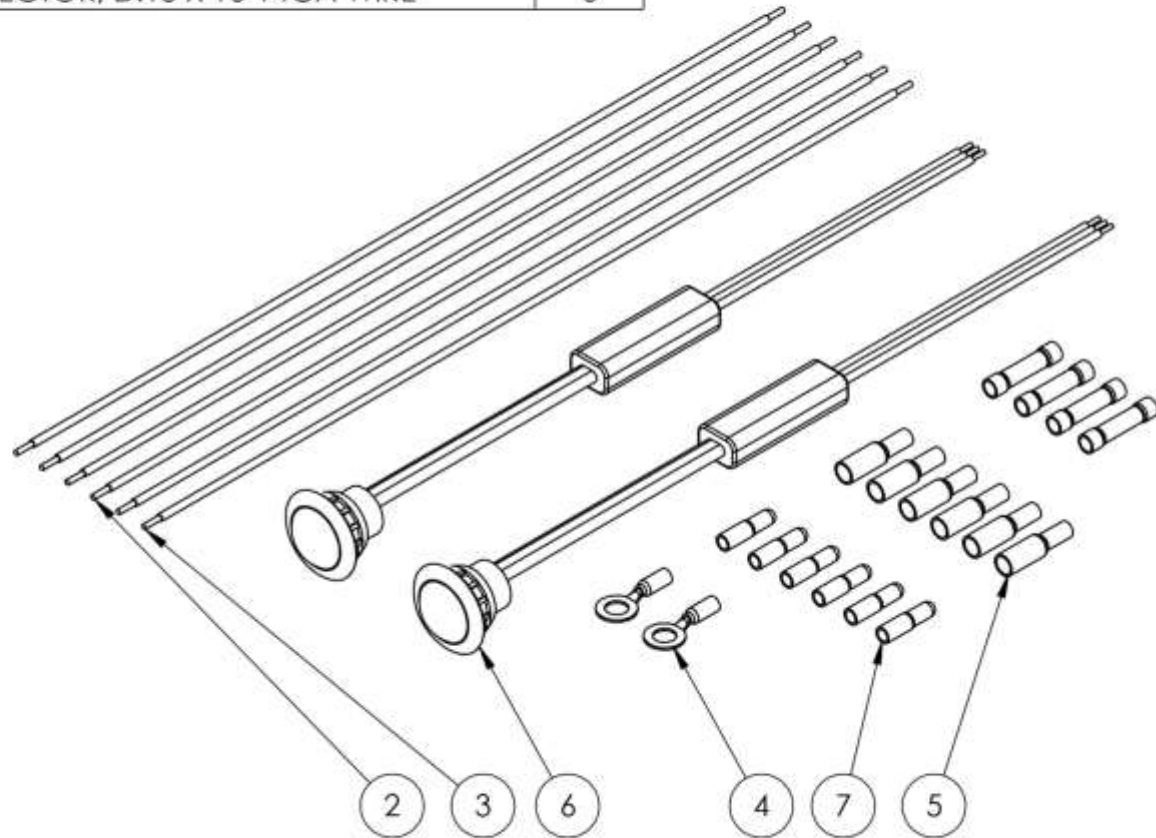

## Section 3: Pre-Installation

Step 1: **WARNING**

**DO NOT CUT OFF ANY FACTORY PLUGS UNLESS INSTRUCTED!!!**



## Section 3: Pre-Installation

### Step 2: Prepare Light Harness

- A. Add a Male Bullet Connector to the Red Lead, Black Lead, and White Lead.
- B. Add a Female Bullet Connector to the end of a piece of 16GA White Wire, and a 1/4" Ring Terminal to the other end, creating a new Ground Harness.
- C. Add One Female Bullet Connector to the end of two piece of 16GA Red Wire.
- D. Connect the Male Bullet Connector to the Female Bullet Connector on the 16GA White Wire and connect to White wire on LED. Connect the Male Bullet Connector to the Female Bullet Connector on the two 16GA Red Wire and connect to Red and Black wires on LED. Wrap the connections with Electrical Tape, or use Shrink Wrap.

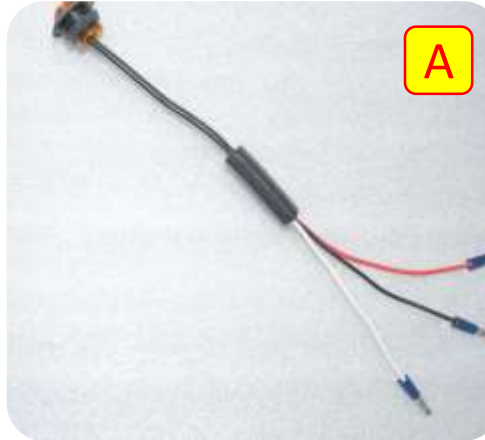

**Note:** The following steps are for a single side; repeat all steps for second side.

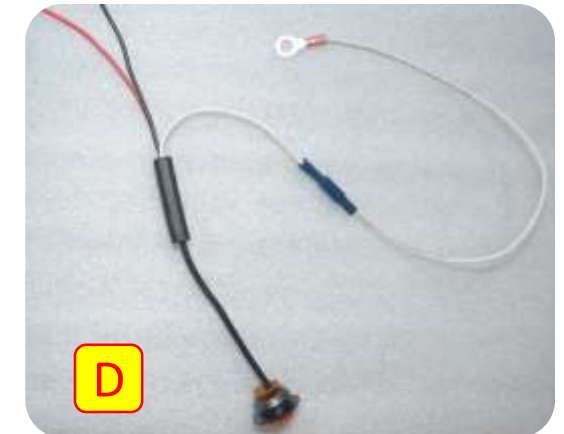

## Section 3: Pre-Installation



### Step 3: **WARNING**

**DO NOT CUT OFF ANY OTHER FACTORY PLUGS OTHER THAN THE ONE INSTRUCTED ON PAGE SEVEN, AS THIS WILL CAUSE ERRADIC ELECTRICAL ISSUES.**

## Section 4: Installation Instructions

### Step 4: Install Light Bodies

- E. Install the LED Marker Lights. The Light with the extended leads goes through the front hole (with Gasket) and then through the 1/2" hole in the Inner Fender Well.
- F. Unplug factory side running/blinker light from housing (holds factory bulb)
- G. Locate the stock side running/blinker light wires and remove from factory sheathing. There will be 2 wires, one for positive blinker and 1 for positive running light. Secure the light socket to the wiring harness.
- H. **DO NOT CUT OFF ANY OTHER FACTORY PLUGS OTHER THAN INSTRUCTED BELOW, AS THIS WILL CAUSE IRADIC ELECTRICAL ISSUES.**
- I. Cut factory light socket off and strip both wires; one of these wires will be the positive blinker and the other the positive running light.

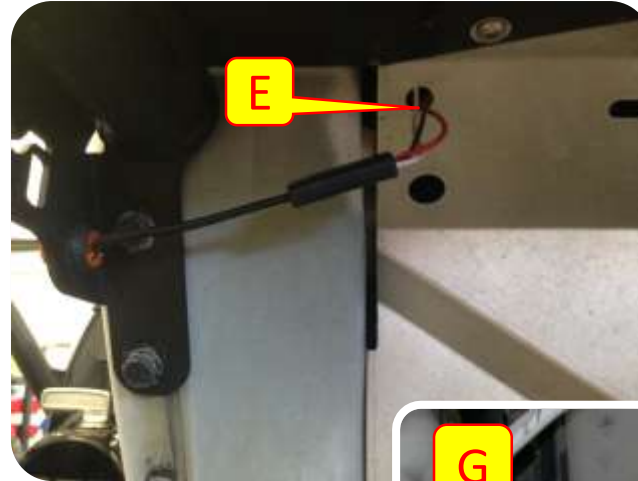



## Section 4: Installation Instructions



### Step 3: Wiring Diagram for MetalCloak Dual Function LED Marker & Blinker Light

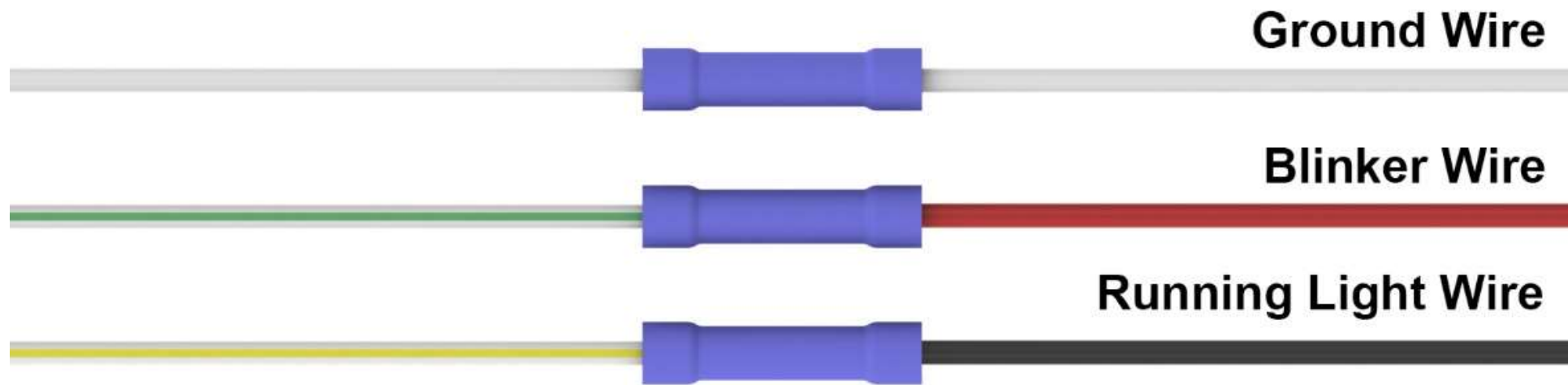

## Section 4: Installation Instructions

### Step 4: Connect Lights to Stock Harness

- J. The WHITE wire on the Dual Function LED Marker/blinker light will be for the GROUND wire. You will need to attach to a ground source.
- K. The BLACK wire on the Dual Function LED Marker/blinker light will be for the BLINKER wire and attaches to the white and yellow striped factory wire.
- L. The RED wire on the Dual Function LED Marker/blinker light will be for the BLINKER wire and attaches to the white and green striped factory wire.
- M. Use a 10MM Wrench to remove the M6 screw that holds the ground wire. Attach the Ground Harness with the Ring.
- N. Enjoy your new Dual Function Led Marker & Blinker Lights.

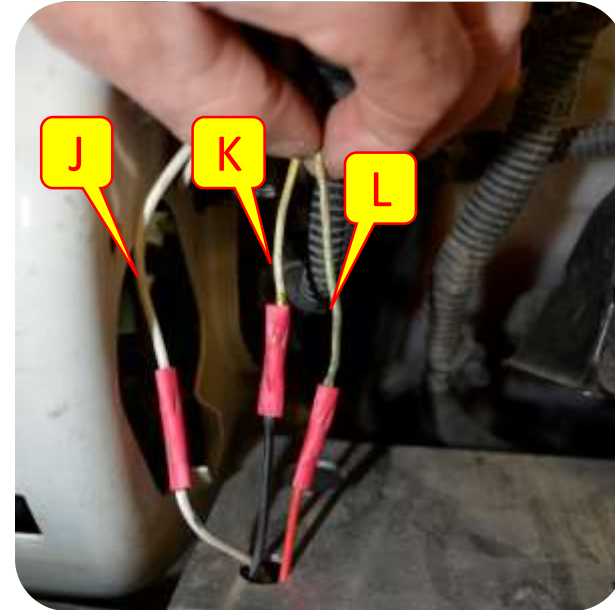

**Note:** Use Electrical Tape or Zip-ties to stow the wires and protect any open connectors.

