



**PRODUCT: JK Molded Housing Rear ExoSkin & ExoCorners**

REV: A | 07-21-2023 | II-3436

**READ INSTRUCTIONS IN FULL BEFORE INSTALLATION.**

**QUESTIONS? CALL 916-631-8071 M-F 7:00 AM – 5:00 PM PST**

The MetalCloak experience includes the ease of installation of our products. We design for most contingencies, but installation may be different based on different Jeep condition, configuration and/or year.

We are continually trying to improve our products and instructions – please help us by providing feedback and pictures if you find any part of the instructions that do not match your particular Jeep or are not easily understandable.









If you have any difficulties at all, please give us a call. Thank you and enjoy your MetalCloak Products!

**IMPORTANT NOTE: We use Stainless Steel Hardware where possible. Therefore, a tube of Silver Anti-seize is provided and should be used on all bolts—only a small amount is needed.**

**WARRANTY INFORMATION:** This article is sold without warranty expressed or implied. No warranty or representation is made as to this products ability to protect the user from injury or death. The user assumes that risk. The effectiveness, warranty and longevity of this equipment are directly related to the manner in which it is INSTALLED, USED and/or MAINTAINED. THE USER ASSUMES ALL RISK. By purchasing this product and opening the packaging, purchasers expressly acknowledge, understand and agree that they take, select and purchase these MetalCloak products from Armored Works, LLC, its affiliates and distributors and agents as is and with all faults. The entire risk as to the quality and performance of these MetalCloak products is with the purchaser. Working on your vehicle can be a dangerous activity. If you are unsure of what you are doing, please leave mechanical or safety critical work to a skilled mechanic. We take no responsibility for the incorrect use and/or installation of MetalCloak products.

## Section 1: Tools & Notes on Installation

**Tools Required:** This list is the recommended tools for ease of installation. Other versions of the same tool can be used. For example, Allen Wrenches instead of Allen Drive Sockets.

	Electric Drill	1/8" Drill 13/32" Drill 3/8" Drill	9/32" Drill 17/32" Drill	
	Ratcheting Socket Wrench	Phillips and Flat Screwdrivers		
	5/32" Hex Drive Socket/Wrench 7/32" Hex Drive Socket/Wrench	9/16" Hex Drive Socket 7, 10 and 13mm Hex Drive Sockets		
	1/2" Wrench/Socket 9/16" Wrench/Socket 3/16" Wrench/Socket	Wire Stripper/Crimper		

**HOW TO USE THIS GUIDE:** The installation guide contains ALL steps for installation. Please read and follow the instructions in order of each page top to bottom, and left to right.

**Jeep Model:** Instructions may apply to multiple Jeep models, but are labeled separately where appropriate (i.e. TJ vs. LJ).

**Options:** Because of the number of component options we offer, these instructions may contain steps that will not match your particular configuration. You can skip these steps.

**Images:** Pictures are provided and parts are labeled throughout the instructions. Each text box contains guidance based on the pictures next to it. The text will refer to alphabetical labels (A, B, etc.) found in the images.

**Installation Notes:** Terms may be used in the body of the instructions that you may not be familiar with, if you have any questions feel free to contact us at the number below, or email [techhelp@metalcloak.com](mailto:techhelp@metalcloak.com)

**QUESTIONS:** Any questions or comments about the instructions? Call us at 916-631-8071 M-F 7:00 AM – 5:00 PM PST.

# Section 2: Product Components

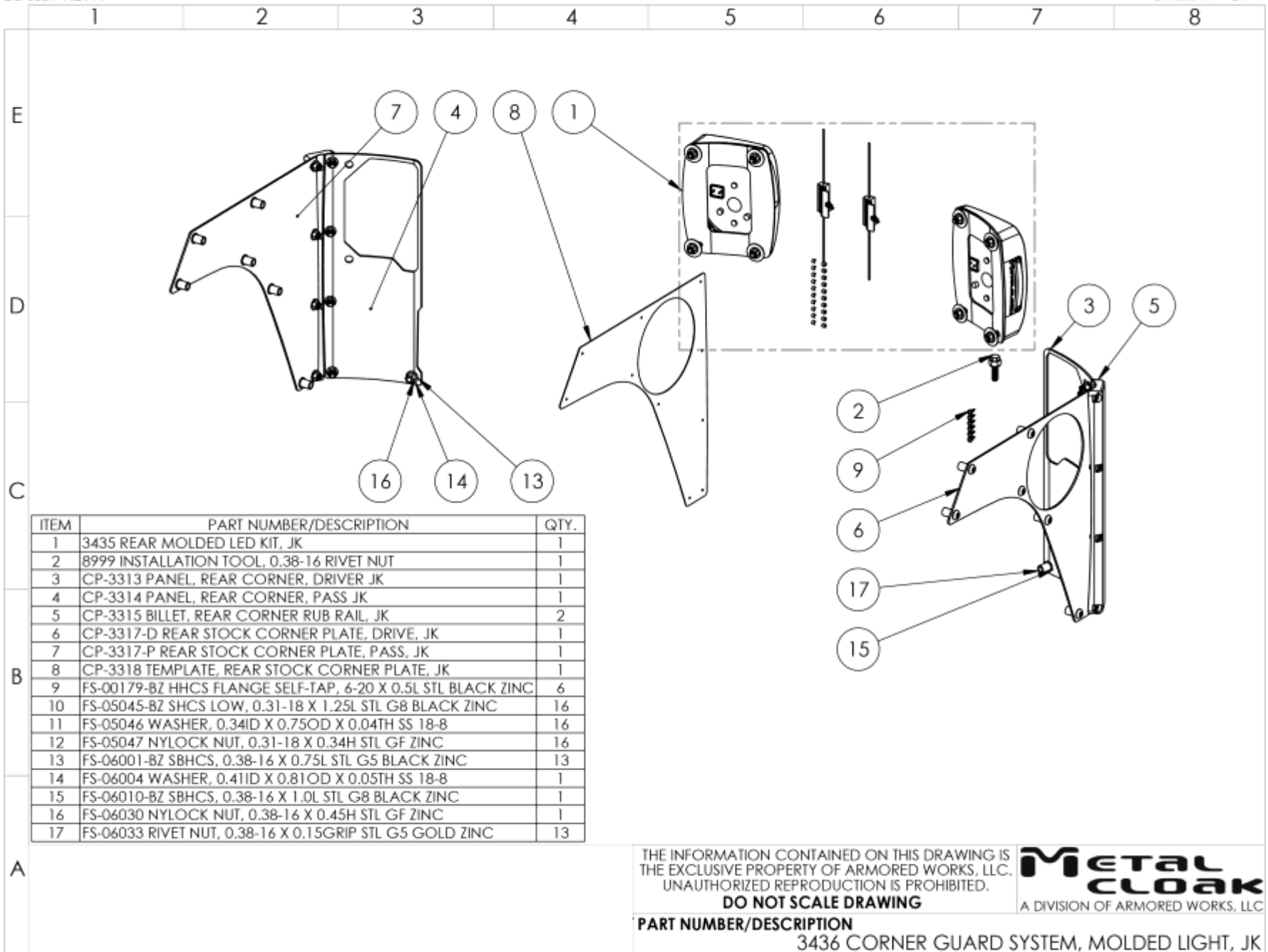

THE INFORMATION CONTAINED ON THIS DRAWING IS THE EXCLUSIVE PROPERTY OF ARMORED WORKS, LLC. UNAUTHORIZED REPRODUCTION IS PROHIBITED.  
**DO NOT SCALE DRAWING**

**Metal Cloak**  
 A DIVISION OF ARMORED WORKS, LLC

**PART NUMBER/DESCRIPTION**  
 3436 CORNER GUARD SYSTEM, MOLDED LIGHT, JK

## Section 3: Installation Instructions

### Step 1: Preparation for Rear Stock Plate Installation

- A. Remove stock rear taillights using a Phillips head Screwdriver (only the 2 screws closest to spare tire). You will need this area open for access later in the install.
- B. **OPTIONAL STEP:** Tape side fender panel and template edges to prevent scratching the paint. Be sure to push holes through tape on template if the tape is now covering them.



## Section 3: Installation Instructions

### Step 2: Align Drill Template & Mark Holes to Be Drilled



- C. Tape drill template in place being sure to get it straight and aligned.
- D. Mark on the top and bottom of the template at the rear body seam (*these marks allow for alignment on opposite side of Jeep when re-using template*).
- E. Once the Template is aligned to your satisfaction drill pilot hole for sheet metal screw using 1/8" drill bit and install sheet metal screw; repeat this action for a total of 3 locations to ensure the template is secure for drilling additional holes.
- F. Use template to drill out all additional holes.
- G. After all holes are drilled remove sheet metal screw that are holding template on and peel template off the jeep.



## Section 3: Installation Instructions

### Step 3: Prepare Jeep for Fender Installation

- H. For an extra step of precaution mask off outside painted surfaces in case of a slip with the drill.
- I. Use 17/32 drill bit to finish drilling out holes for rivet nuts (*See Diagram on page 7*).
- J. With a small paint brush or cotton swab prime the hole edges to prevent premature rust.
- K. Pull tape off body panel.

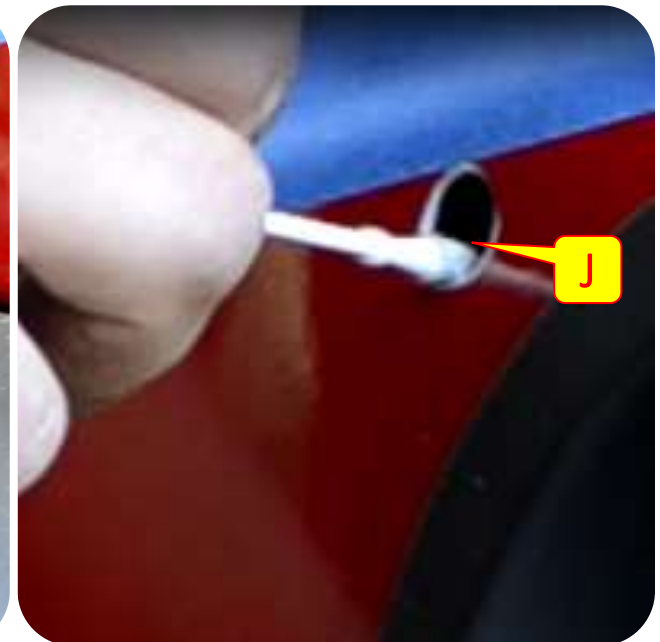
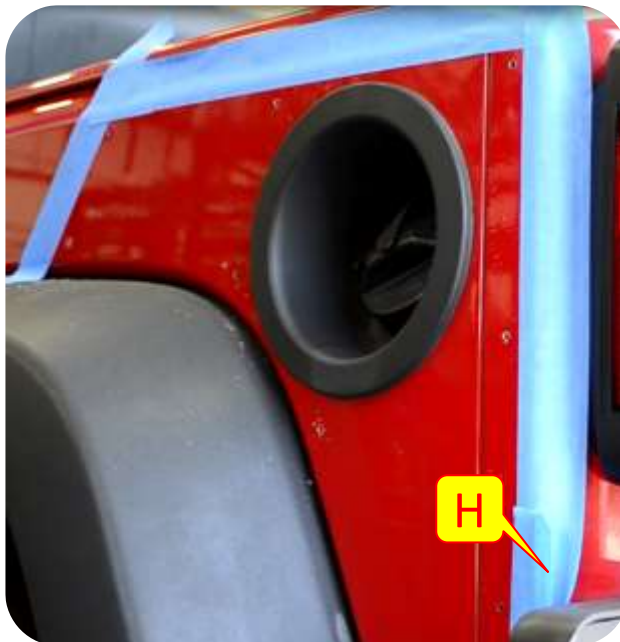

## Section 3: Installation Instructions

### Step 4: Prepare Jeep for Fender Installation



**Note:** We use a step drill after this to chamfer the edges.

- L. Install Rivet nuts in drilled Locations (*See diagram on page 7*).
- M. Drill out pilot holes to 13/32" on rear of Jeep body behind the seam (*See diagram on page 7*).
- N. With a small paint brush or cotton swab prime the hole edges to prevent premature rust.
- O. Carefully wipe metal shards from paint surface.



## Section 3: Installation Instructions

### Step 4: Prepare Jeep for Corner Plates Installation

**Important Note:** *TAKE YOUR TIME!* Drill holes according to the diagram below. The more precise you are in locating and drilling the Rivet Nut holes in the tub, the more easily the Stock Corner Plates will bolt into position. Remember to step up in drill size, starting at 1/8" and moving up to the appropriate size [A, bottom of page]. *Moving directly to the final drill size is STRONGLY DISCOURAGED; the stock sheet metal is very thin, and the drill can easily catch and rip instead of drilling cleanly and providing a clean, centered finish hole.* Be sure to drill through all layers of sheet metal to account for the depth of the Rivet Nuts.

- Drill to 17/32"; pre-drill at 1/8" and work up
- ▲ Drill to 13/32"; pre-drill at 1/8" and work up

- Install 3/8"-16 Rivet Nuts
- ▲ Backed by 3/8"-16 Nylon Lock Nuts

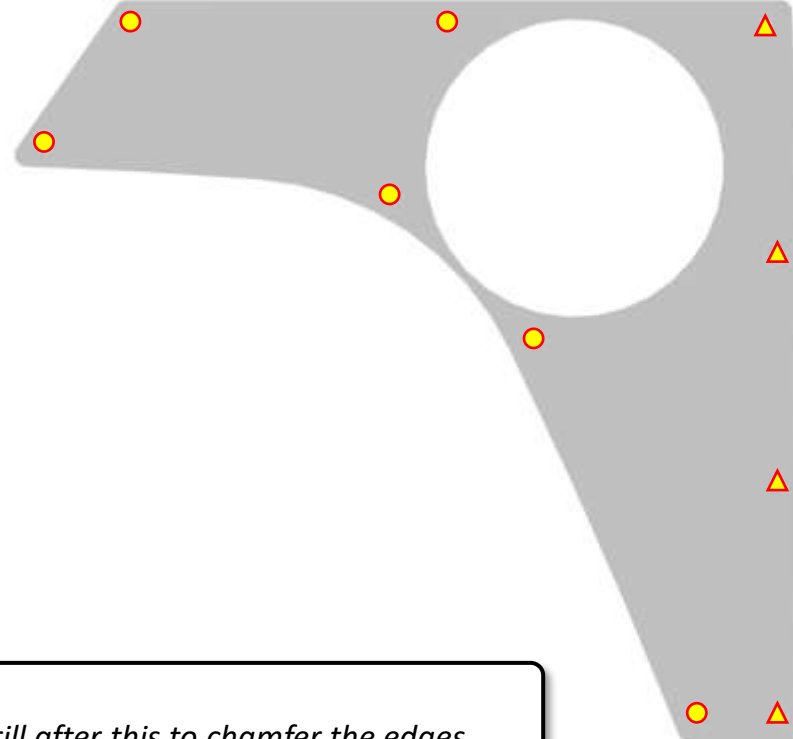

**Note:** *We use a step drill after this to chamfer the edges.*



## Section 3: Installation Instructions

### Step 5: Install Fender Base

- P. Place corner plate on Jeep and loosely fasten with bolt into rivet nuts.
- Q. Align panel and tighten all hardware.
- R. Enjoy the new look and added protection of the JK Corner Plates on you Jeep.



## Section 3: Installation Instructions

### Step 6: Prepare Tub for ExoCorner Installation

- S. Remove your license plate using a Phillips screwdriver, and then use a 7MM Socket to remove the 4 stock screws holding the License Plate Bracket in place.
- T. Unplug the license plate light and push the harness inside the tub; you will need to re-locate the light and license plate with this kit.
- U. Remove the stock light nut clips; a pair of pliers may be helpful.
- V. You will also need to bend the stock tab back into the tub about 1/8"-1/4"; a couple light hits with a rubber mallet should suffice (*this is simply to create clearance for the LED light body*).

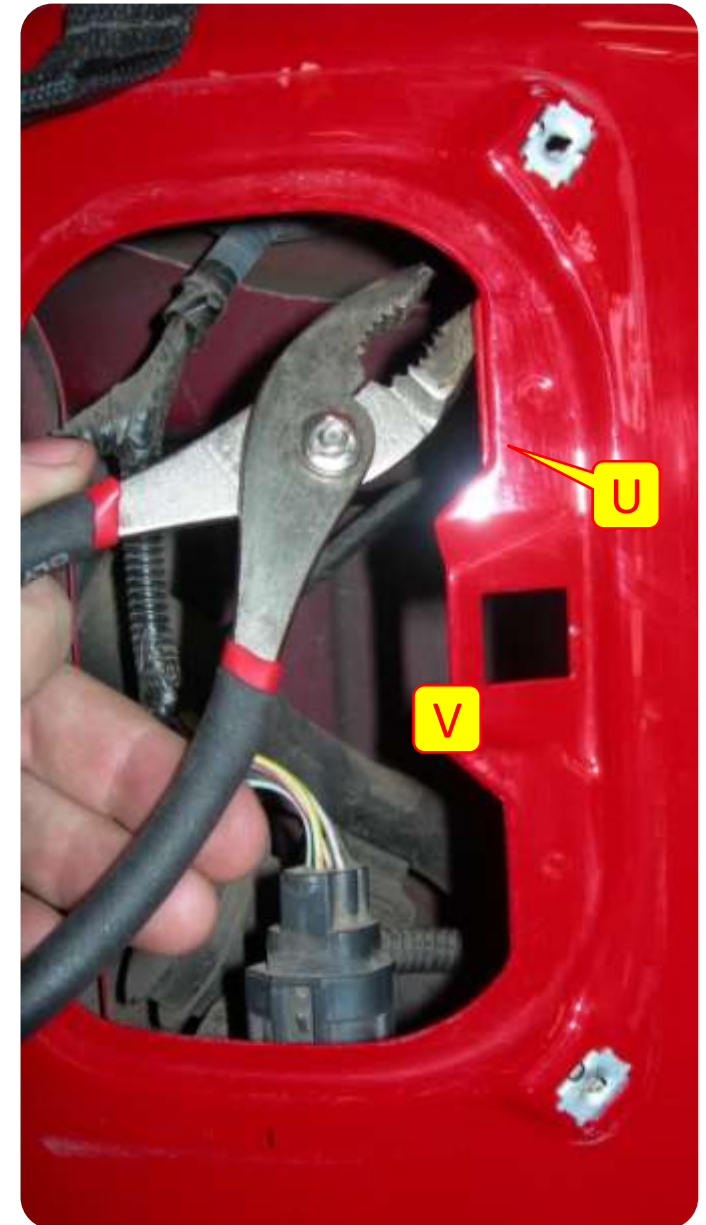
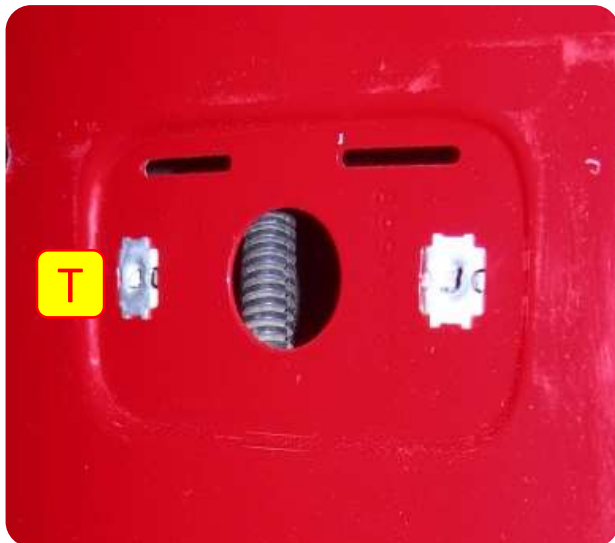

## Section 3: Installation Instructions

### Step 6: Prepare Tub for ExoCorner Installation

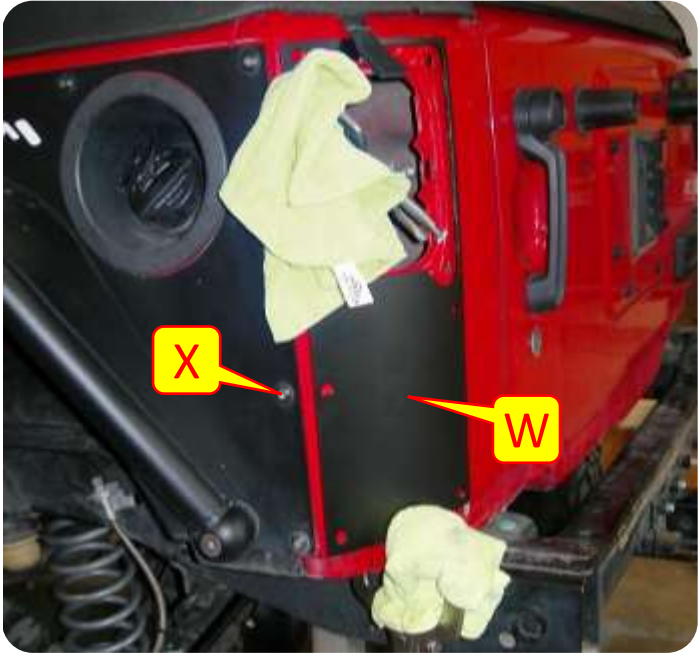

- W. Clamp the Rear Corner Panel in place. To prevent scratching the powder coat we recommend that you put a rag or towel between the clamp and the panel.
- X. If you have the MetalCloak Rear Base Plates you will need to remove the four 3/8"-16 Socket Button Screws and hardware at the rear of the Base Plate. Use these existing holes and the Corner Rub Rail to best align the Corner Panel.
- Y. The inside corners of the Corner Panel will hug the stock light bosses very tightly when properly aligned. The holes in the LED Light Bezel should align closely with the stock square holes in the tub.
- Z. Mark all holes to be drilled with a center punch or a permanent marker. Remove the Panels and drill all holes to 3/8" [●]. One hole on the Driver's side will need to be opened up to 17/32" [▲].



## Section 3: Installation Instructions

### Step 7: Install Corner Guard

- AA. As mentioned, you will need to install a 3/8" Rivet Nut in the tub. See our separate Rivet Nut Installation Guide for additional instruction and/or guidance on this process.
- BB. We recommend that you apply a small amount of primer or matching paint to all drilled surfaces to help prevent rust; a 'Q-tip' can be helpful in this process.
- CC. Install the Corner Rub Rail and the LED Light Bezel components using the provided 5/16"-18 Low Socket Cap Screws [●]. Each screw will be backed by a 5/16" Washer and Nylon Lock Nut. Do not fully tighten the hardware, and do not install the LED light yet.
- DD. The bottom, inner holes will use the provided 3/8"-16 Socket Button Cap Screws [▲].

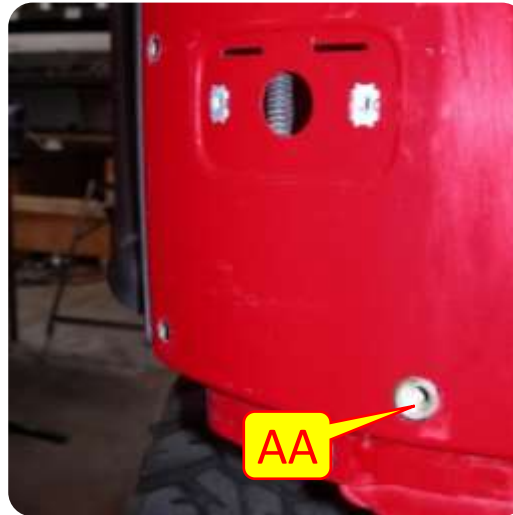

## Section 3: Installation Instructions

### Step 8: Preparation for Taillight Installation

- DD. Align the light bezel with the stock holes. The cut-outs in the rear of the bezel cover the stamped “peaks” in the tub sheet metal and mark the location of the additional holes.
- EE. Drill the marked locations to 3/8”. We recommend painting any exposed metal to prevent rust.
- FF. Align Bezel and loosely install using the provided hardware (*the washers go behind the stock clip locations*).
- GG. Cut the plug at the base of the stock bulbs and unwrap the wires (*if you prefer, you can wire directly to the JEEP’s harness, but we recommend recycling the plug from the stock light for easier future access*).

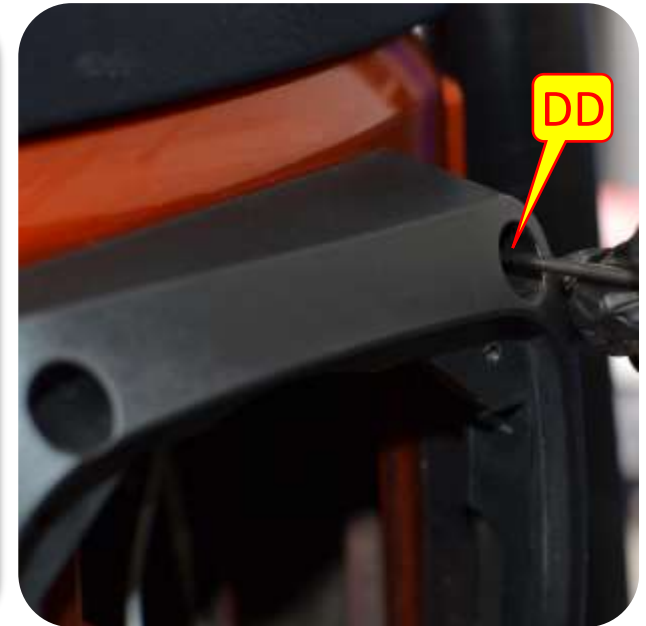

## Section 3: Installation Instructions

### Step 9: Taillight Wiring

**Note:** Stagger the length of the wires so that when all the butt connectors are installed, they will not overlap; this makes heat shrinking or taping the wires much easier. The order of the stagger is not important.

- HH. Use butt connectors to wire the stock plug and provided resistor to the LED according to the provided wiring diagram. Tape or shrink-wrap as preferred.
- II. Use the provided self tapping screws and tap the aluminum resistor bracket with a Philips head screwdriver.

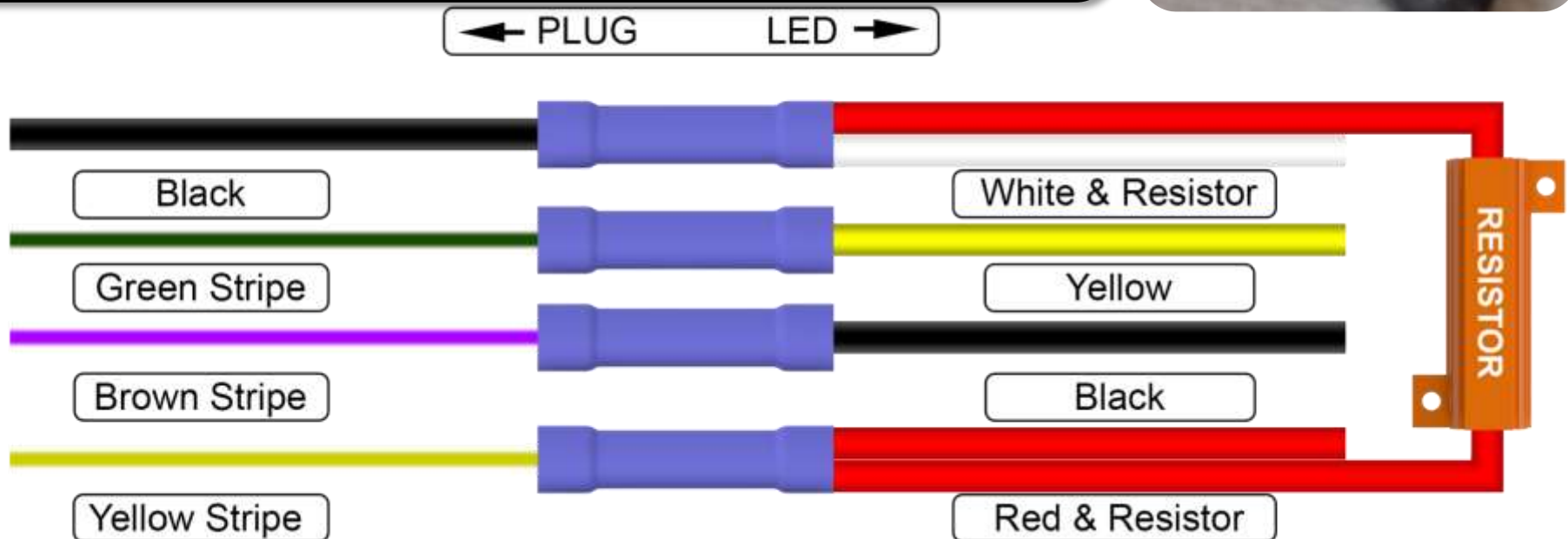

## Section 3: Installation Instructions

### Step 10: Taillight Bezel Installation

- JJ. Remove the screws and install the resistor to the bracket with a Philips head screwdriver.
- KK. Using a 5/32" allen and 1/2" wrench tighten the light housing to the Jeep.
- LL. Plug the light into the socket.



## Section 3: Installation Instructions

### Step 11: Taillight Resistor Installation

MM. Install the provided clip to the resistor bracket.

NN. Find a flat surface and clip the resistor bracket to the interior of the jeep tub.





## Section 3: Installation Instructions

### Step 12: Taillight LED Installation

- OO. Slide the side marker light through the side of the light bezel and install using a Philips head screwdriver and a 3/16 socket or wrench.
- PP. Using a Phillips head screwdriver install the LED light into the beveled light mount with the provided Phillips head screws.

