



PRODUCT: TJ/LJ Upper Rear Control Arms

REV: D | 05-05-2021 | II-7052/7072

READ INSTRUCTIONS IN FULL BEFORE INSTALLATION.
QUESTIONS? CALL 916-631-8071 M-F 7:00 AM – 5:00 PM PST

The MetalCloak experience includes the ease of installation of our products. We design for most contingencies, but installation may be different based on different Jeep condition, configuration and/or year.

We are continually trying to improve our products and instructions – please help us by providing feedback and pictures if you find any part of the instructions that do not match your particular Jeep or are not easily understandable.

If you have any difficulties at all, please give us a call. Thank you and enjoy your MetalCloak Products!

IMPORTANT NOTE: We use Stainless Steel Hardware where possible. Therefore, a tube of Silver Anti-seize is provided and should be used on all bolts—only a small amount is needed.

WARRANTY INFORMATION: This article is sold without warranty expressed or implied. No warranty or representation is made as to this products ability to protect the user from injury or death. The user assumes that risk. The effectiveness, warranty and longevity of this equipment are directly related to the manner in which it is INSTALLED, USED and/or MAINTAINED. THE USER ASSUMES ALL RISK. By purchasing this product and opening the packaging, purchasers expressly acknowledge, understand and agree that they take, select and purchase these MetalCloak products from Armored Works, LLC, its affiliates and distributors and agents as is and with all faults. The entire risk as to the quality and performance of these MetalCloak products is with the purchaser. Working on your vehicle can be a dangerous activity. If you are unsure of what you are doing, please leave mechanical or safety critical work to a skilled mechanic. We take no responsibility for the incorrect use and/or installation of MetalCloak products.

Section 1: Tools & Notes on Installation



Tools Required: This list is the recommended tools for ease of installation. Other versions of the same tool can be used. For example, Allen Wrenches instead of Allen Drive Sockets.



Socket & Ratchet Wrench

15MM Socket
19MM Socket (*Big Bolt Upgrade*)



Drill (*Optional*)

1/2" Drill Bit (*Big Bolt Option*)



HOW TO USE THIS GUIDE: The installation guide contains ALL steps for installation. Please read and follow the instructions in order of each page top to bottom, and left to right.

Jeep Model: Instructions may apply to multiple Jeep models, but are labeled separately where appropriate (i.e. TJ vs. LJ).

Options: Because of the number of component options we offer, these instructions may contain steps that will not match your particular configuration. You can skip these steps.

Images: Pictures are provided and parts are labeled throughout the instructions. Each text box contains guidance based on the pictures next to it. The text will refer to alphabetical labels (A, B, etc.) found in the images.

Installation Notes: Terms may be used in the body of the instructions that you may not be familiar with, if you have any questions feel free to contact us at the number below, or email techhelp@metalcloak.com

QUESTIONS: Any questions or comments about the instructions? Call us at 916-631-8071 M-F 7:00 AM – 5:00 PM PST.

Section 2: Product Components

DC-0001 REV A

SHEET 1 OF 2

ITEM	PART NUMBER/DESCRIPTION	QTY.
1	7052-1 CONTROL ARMS, TJ-LJ REAR UPPER HK-7052	2
2	FM-10138 HHCS, M10-1.5 x 90L STL C10.9 ZINC	4
3	FM-10139 WASHER, 10.5ID X 20OD X 1.8TH STL ZINC	8
4	FM-10140 TOPLOCK NUT, M10-1.5L X 8H STL C10 ZINC	4

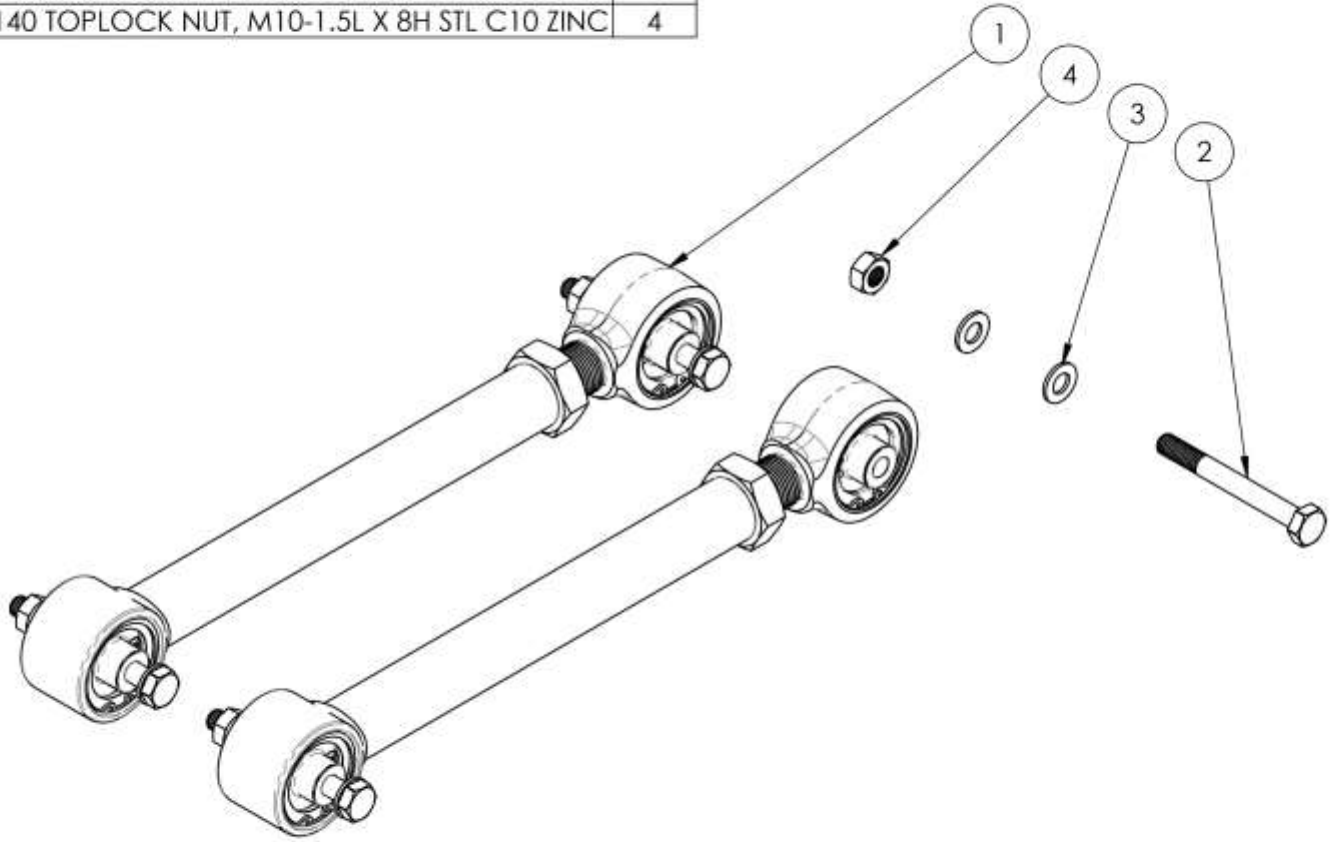

THE INFORMATION CONTAINED ON THIS DRAWING IS THE EXCLUSIVE PROPERTY OF ARMORED WORKS, LLC. UNAUTHORIZED REPRODUCTION IS PROHIBITED.
DO NOT SCALE DRAWING

Metal Cloak
 A DIVISION OF ARMORED WORKS, LLC

PART NUMBER/DESCRIPTION
 7052 CONTROL ARM PAIR, TJ-LJ REAR UPPER

Section 3: Installation Instructions

Step 2: Disconnect Rear Upper Control Arms

- A. Remove the E-brake from the upper control arms using a 13mm socket. Remove brackets from the E-brake cables.
- B. Un-bolt one upper control arm using a 15mm socket and wrench. Discard bolts but keep the tab nut to install later.

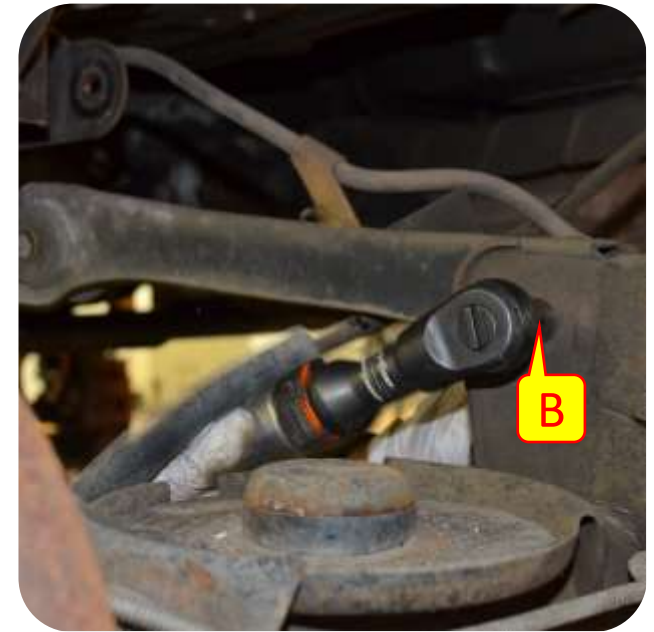
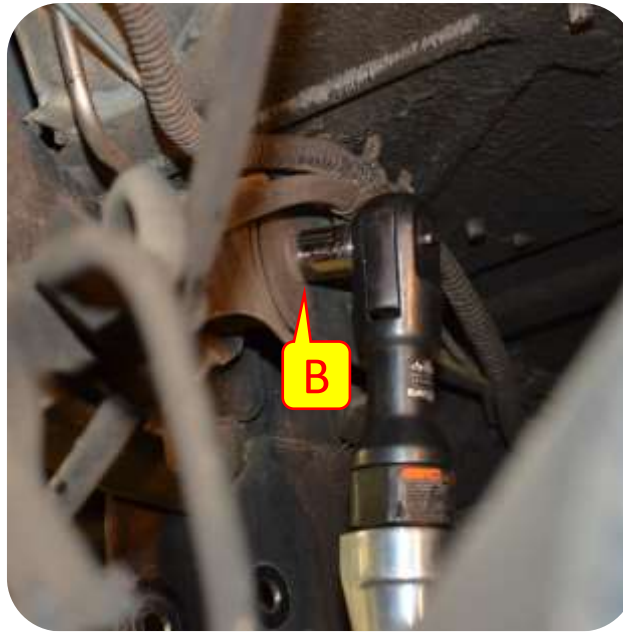

Section 3: Installation Instructions



Step 3: Install MetalCloak Rear Upper Control Arms

- C. Set your new control arm to the suggested lengths as shown in the chart.
- D. Install upper control arm using new hardware and the factory tab nut.
- E. Repeat steps for other side.
- F. The E-brake cable should go in between the upper and lower control arms.

Traditional Single Adjustable Duroflex Control Arms

Part #	Location	3.5" Kit Length	Minimum	Maximum
7050	Lower Front	16.63"	15.5"	16.63"
7050	Lower Rear	16"	15.5"	16.63"
7051	Upper Front	15"	14.88"	15.63"
7052	Upper Rear	14"	13.5"	14.63"

Note: *These measurements are just a starting point, the final length varies between vehicles.*

Important Note: *If you chose the Big Bolt option of upgrading your hardware & joint to the larger bolt size drill out the control arm brackets to 1/2". Use a 19mm (3/4") socket and wrench to tighten. Otherwise, use the stock sized hardware in the stock hole.*

