



Installation Instructions



PRODUCT: JK Full RockSport Steering System

REV: A | 09-28-2020 | II-7134

**READ INSTRUCTIONS IN FULL BEFORE INSTALLATION.
QUESTIONS? CALL 916-631-8071 M-F 7:00 AM – 5:00 PM PST**

The MetalCloak experience includes the ease of installation of our products. We design for most contingencies, but installation may be different based on different Jeep condition, configuration and/or year.

We are continually trying to improve our products and instructions – please help us by providing feedback and pictures if you find any part of the instructions that do not match your particular Jeep or are not easily understandable.

If you have any difficulties at all, please give us a call. Thank you and enjoy your MetalCloak Products!

IMPORTANT NOTE: We use Stainless Steel Hardware where possible. Therefore, a tube of Silver Anti-seize is provided and should be used on all bolts—only a small amount is needed.

WARRANTY INFORMATION: This article is sold without warranty expressed or implied. No warranty or representation is made as to this products ability to protect the user from injury or death. The user assumes that risk. The effectiveness, warranty and longevity of this equipment are directly related to the manner in which it is INSTALLED, USED and/or MAINTAINED. THE USER ASSUMES ALL RISK. By purchasing this product and opening the packaging, purchasers expressly acknowledge, understand and agree that they take, select and purchase these MetalCloak products from Armored Works, LLC, its affiliates and distributors and agents as is and with all faults. The entire risk as to the quality and performance of these MetalCloak products is with the purchaser. Working on your vehicle can be a dangerous activity. If you are unsure of what you are doing, please leave mechanical or safety critical work to a skilled mechanic. We take no responsibility for the incorrect use and/or installation of MetalCloak products.

Section 1: Tools & Notes on Installation



Tools Required: This list is the recommended tools for ease of installation. Other versions of the same tool can be used. For example, Allen Wrenches instead of Allen Drive Sockets.



Ratchet

Hammer

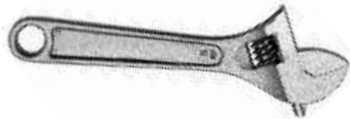

Large Adjustable Wrench

9/16" Wrench
3/4" Wrench



10mm Socket 14mm Socket
18mm Socket 19mm Socket
21mm Socket 22mm Socket
24mm Socket 15/16" Socket
17mm Socket

Tape Measure



3/16" Allen Socket



HOW TO USE THIS GUIDE: The installation guide contains ALL steps for installation. Please read and follow the instructions in order of each page top to bottom, and left to right.

Jeep Model: Instructions may apply to multiple Jeep models, but are labeled separately where appropriate (i.e. TJ vs. LJ).

Options: Because of the number of component options we offer, these instructions may contain steps that will not match your particular configuration. You can skip these steps.

Images: Pictures are provided and parts are labeled throughout the instructions. Each text box contains guidance based on the pictures next to it. The text will refer to alphabetical labels (A, B, etc.) found in the images.

Installation Notes: Terms may be used in the body of the instructions that you may not be familiar with, if you have any questions feel free to contact us at the number below, or email techhelp@metalcloak.com

QUESTIONS: Any questions or comments about the instructions? Call us at 916-631-8071 M-F 7:00 AM – 5:00 PM PST.

Section 2: Product Components

DC-0001 REV A

SHEET 1 OF 4

ITEM	PART NUMBER/DESCRIPTION	QTY
1	7134-1 STEERING SYSTEM UPGRADE, ROCKSPORT, JK	1

OPTION 1
 STEEL - 7686 STEERING STABILIZER 1.63IN TIE ROD MOUNT
 ALUMINUM - 7687 STEERING STABILIZER 1.63IN BILLET MOUNT

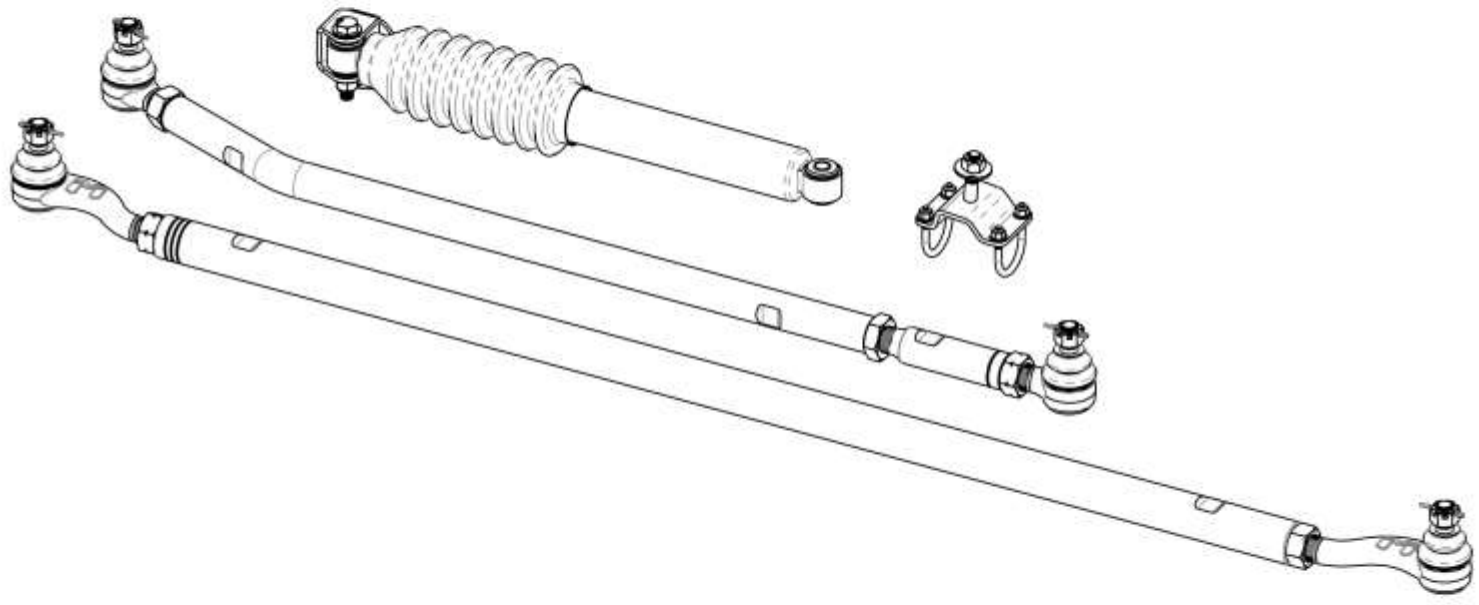

THE INFORMATION CONTAINED ON THIS DRAWING IS THE EXCLUSIVE PROPERTY OF ARMORED WORKS, LLC. UNAUTHORIZED REPRODUCTION IS PROHIBITED.
DO NOT SCALE DRAWING

MetalCloak
 A DIVISION OF ARMORED WORKS, LLC

PART NUMBER/DESCRIPTION
 7134 STEERING SYSTEM UPGRADE, ROCKSPORT, JK

Section 3: Installation Instructions



IMPORTANT NOTE: *Stick on wheel weights are recommend, clip on weights "may" have a slight interference.*

Section 3: Installation Instructions

Step 1: Preparation for Tie Rod

- A. Use a jacks to support the front axle of the jeep while you remove the wheels.
- B. Using a 18mm socket disconnect the tie rod end of the factory stabilizer.
- C. Using a 18mm socket disconnect the axle end of the factory stabilizer.
- D. Use a 21mm socket to remove the nuts at each end of the tie rod. Remove tapered studs from knuckles. You may need to hit with a hammer or use a tie rod removal tool to remove.

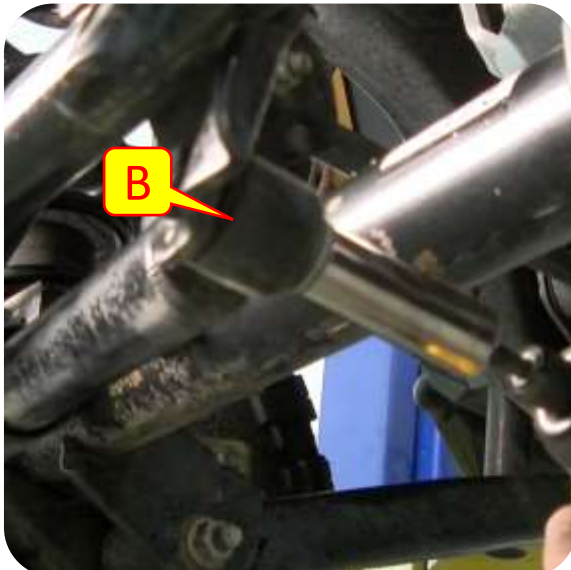

Section 3: Installation Instructions

Step 2: Install Tie Rod

- E. Assemble tie rod ends on tie rod. (Tie Rod ends have different handed threads and the rod is made accordingly).
- F. Insert the bolts at each end of the tie rod into the knuckle on each side of the car.
- G. Use 15/16" socket to tighten the nut on the top of the bolt connected to the tie rod. Insert cotter pin and bend the ends around the bolt in opposite directions.



Section 3: Installation Instructions

Step 3: Install Tie Rod Stabilizer Mount

- H. Place the new bracket on top of the tie rod as shown in the picture. Add the U-bolts, nylock nuts, and washers to hold the plate in place.



Section 3: Installation Instructions

Step 4: Install Steering Stabilizer Axle Mount

- I. Using a 21mm socket disconnect the track bar on the axle side (*passenger side*) and remove from bracket. **Keep Hardware.**
- J. Install the axle bracket using the provided hardware hand tight.
- K. Using the stock hardware reinstall the axle side of the track bar.
- L. Tighten the axle side bracket using a 14mm socket.



Section 3: Installation Instructions

Step 5: Install the RockSport Steering Stabilizer

- M. Measure the RockSport steering stabilizer to approximately 16" eye to eye.
- N. Install the axle side of the RockSport steering stabilizer using the provided hardware hand tight.
- O. Move the tie rod bracket to the new location and tighten the tie rod end of the stabilizer with an 19mm socket.
- P. Tighten the axle side of the stabilizer with a 19mm socket and wrench.
- Q. Tighten the tie rod mount to the tie rod using a 10mm socket.

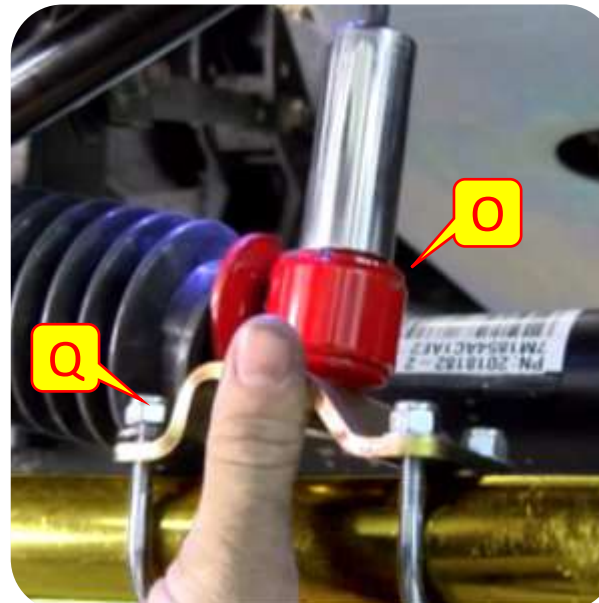

Section 3: Installation Instructions



Step 6: Install Drag Link

- R. Remove stock drag link.
- S. Install the MetalCloak JK Drag Link, preferable the passenger side first. The side of the drag link to be installed in the passenger side will have the bend in it. An extra pair of hands will be useful in holding the other side of the drag link. Use the provided castle nut and only snug the castle nut for now (you will fully tighten everything at the end).
- T. Install the other side of the MetalCloak JK Drag Link. You may need to turn the tires in order to install the drag link. Use the provided castle nut and only snug the castle nut for now.

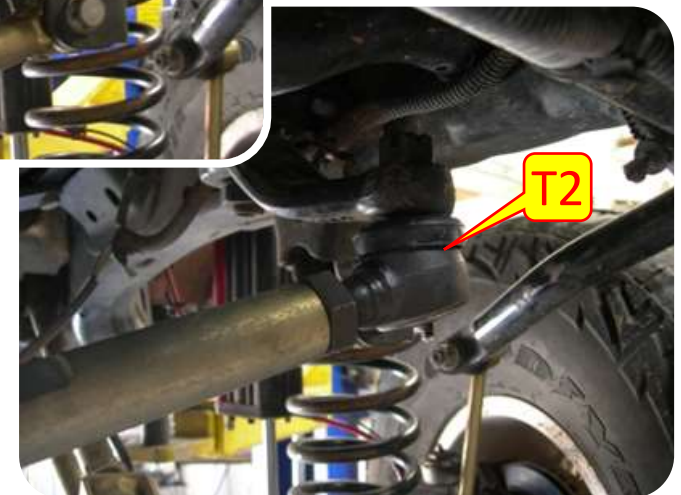

Section 3: Installation Instructions

Step 6: Install Drag Link

- U. Fully tighten and align the castle nuts on both ends of the Drag Link with a 1/2" ratchet and a 24mm socket. Insert and bend the cotter pin to secure the castle nut from loosening.

Note: Before Continuing on to the next step make sure wheels are straight.

- V. Turn the Drag Link Adjuster, either using your hand or an adjustable wrench, whichever is easier, until the steering wheel is level.

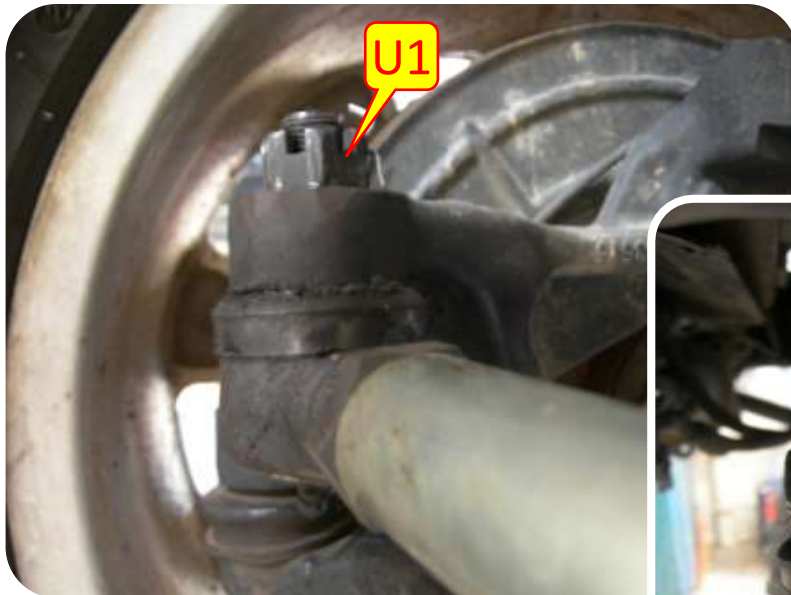

Section 3: Installation Instructions

Step 6: Install Drag Link

- W. Tighten both Jam Nuts.
- X. MetalCloak **STRONGLY RECOMMENDS** having your alignment checked by a professional after changing any suspension components.



Section 3: Installation Instructions

Step 7: Billet Mount Option

Important Note: MetalCloak highly recommends using anti-seize on all bolts.

- A. Using the provided allen head bolts loosely mount the billet bracket to the tie rod.
- B. Turn the steering wheel all the way driver and fully extend the steering stabilizer.
- C. Move the billet mount to the new location and install the stabilizer hand tight using the provided washer and bolt.
- D. Using a 3/16" allen socket tighten the bolts of billet mount to the tie rod. Make sure the bolts are tightened evenly.
- E. Using a 17mm socket tighten the stabilizer bolt.

