



PRODUCT: **Duroflex Front Axle Bushing Kit**

REV: A | 08-03-2018 | II-7349

READ INSTRUCTIONS IN FULL BEFORE INSTALLATION.
QUESTIONS? CALL 916-631-8071 M-F 7:00 AM – 5:00 PM PST

The MetalCloak experience includes the ease of installation of our products. We design for most contingencies, but installation may be different based on different Jeep condition, configuration and/or year.

We are continually trying to improve our products and instructions – please help us by providing feedback and pictures if you find any part of the instructions that do not match your particular Jeep or are not easily understandable.

If you have any difficulties at all, please give us a call. Thank you and enjoy your MetalCloak Products!

IMPORTANT NOTE: We use Stainless Steel Hardware where possible. Therefore, a tube of Silver Anti-seize is provided and should be used on all bolts—only a small amount is needed.

SUSPENSION WARRANTY INFORMATION: MetalCloak products are warranted to be free of defects in material and workmanship for one year from the original purchase date. All products produced by MetalCloak are designed exclusively for off road applications and therefore do not have any warranty or guarantee of performance. No warranty or representation is made as to this products ability to protect the user from injury or death. The user assumes that risk. Because of the wide variety of applications of our products, the effectiveness, warranty and longevity of this equipment are directly related to the manner in which it is installed, used and/or maintained. The entire risk as to the quality and performance of these MetalCloak products is with the purchaser. Working on your vehicle can be a dangerous activity. If you are unsure of what you are doing, please leave mechanical or safety critical work to a skilled mechanic. We take no responsibility for how MetalCloak products are installed.

Section 1: Tools & Notes on Installation



Tools Required: This list is the recommended tools for ease of installation. Other versions of the same tool can be used. For example, Allen Wrenches instead of Allen Drive Sockets. Be sure to use metric on metric and SAE on SAE.



Socket & Ratchet Wrench

18mm Socket
19mm Socket



Welder

Black Spray Paint
(Optional)



Cut-Off Disc and Grinder

Safety Glasses



Synthetic Silicon/Teflon Lubricant

Snap Ring Pliers



Tape Measure

Section 2: Product Components

DC-0001 REV A

SHEET 1 OF 1

ITEM	PART NUMBER/DESCRIPTION	QTY.
1	SS-1027 DUROFLEX PRESS-IN HOUSING, 1.8D X 1.38W	2
2	SS-1029 RETAINING WASHER, 1.63 DIA	4
3	SS-1033-K DUROFLEX BUSHING, 1.8D X 2.0L X .51ID	2
4	SS-1056 INT RET RING, 1.63 BORE YEL ZINC	2
5	SS-1127 BILLET TOWER, DUROFLEX PRESS-IN JOINT, FRONT TJ	1

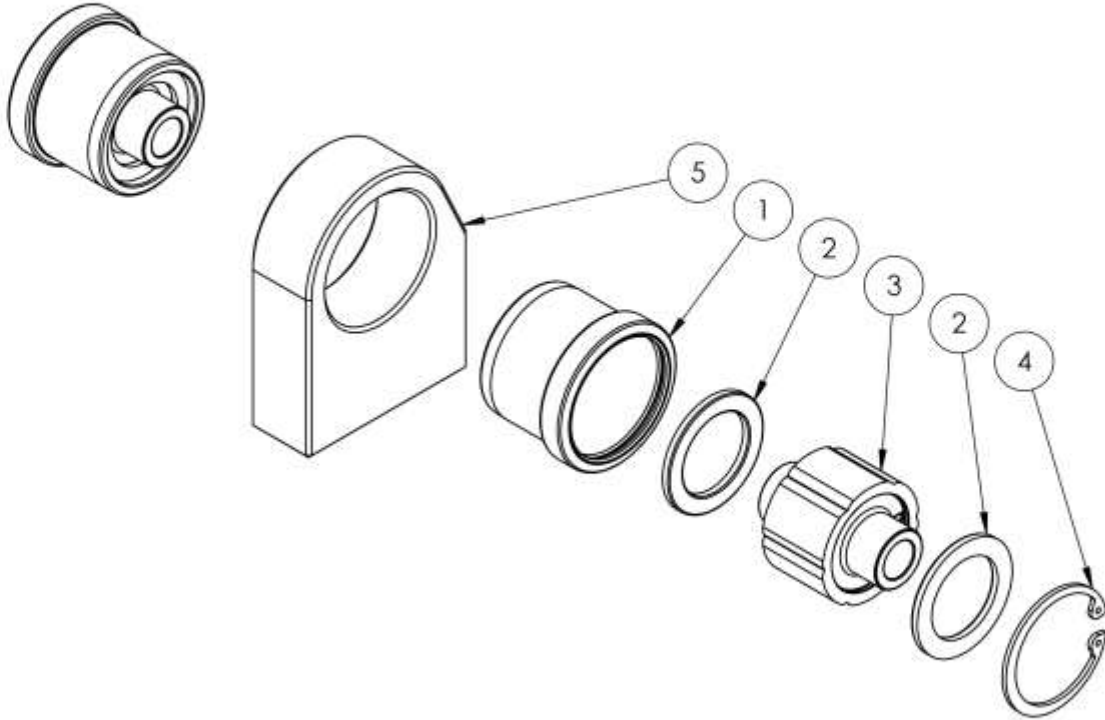

THE INFORMATION CONTAINED ON THIS DRAWING IS THE EXCLUSIVE PROPERTY OF ARMORED WORKS, LLC. UNAUTHORIZED REPRODUCTION IS PROHIBITED.
DO NOT SCALE DRAWING

Metal Cloak
 A DIVISION OF ARMORED WORKS, LLC

PART NUMBER DESCRIPTION 7349 DUROFLEX AXLE BUSHING KIT, FRONT TJ

Section 3: FRONT SUSPENSION Installation Instructions



HOW TO USE THIS GUIDE: The installation guide should be used as a reference for installation. Please read and follow the instructions in order of each page top to bottom, and left to right.

Jeep Model: Instructions may apply to multiple Jeep models, but are labeled separately where appropriate (i.e. TJ vs. LJ).

Options: Because of the number of component options we offer, these instructions may contain steps that will not match your particular configuration. You can skip these steps.

Images: Pictures are provided and parts are labeled throughout the instructions. Each text box contains guidance based on the pictures next to it. The text will refer to alphabetical labels (A, B, etc.) found in the images.

Installation Notes: Terms may be used in the body of the instructions that you may not be familiar with, if you have any questions feel free to contact us at the number below, or email techhelp@metalcloak.com

QUESTIONS: Any questions or comments about the instructions? Call us at 916-631-8071 M-F 7:00 AM – 5:00 PM PST.

Step 1: Remove Stock Components

Important Note: *This installation may be done on the ground and should be done one side at a time to closer match the caster that has already been set. If you are using a lift you must remove the lower side of the track bar off of the front axle to keep the track bar from pulling the axle off center before raising the Jeep.*

Section 3: FRONT SUSPENSION Installation Instructions



Step 1: Remove Stock Components

- A. Remove the passenger side upper front control arm from the axle.
- B. Measure 3 inches from the top of the axle tube on the tower and mark.
- C. Cut the tower to the specified height using a cut off wheel. The remaining tower will be used to locate the assembly.
- D. Prep remaining area for welding by grinding the axle bracket edges and removing any surface coating.

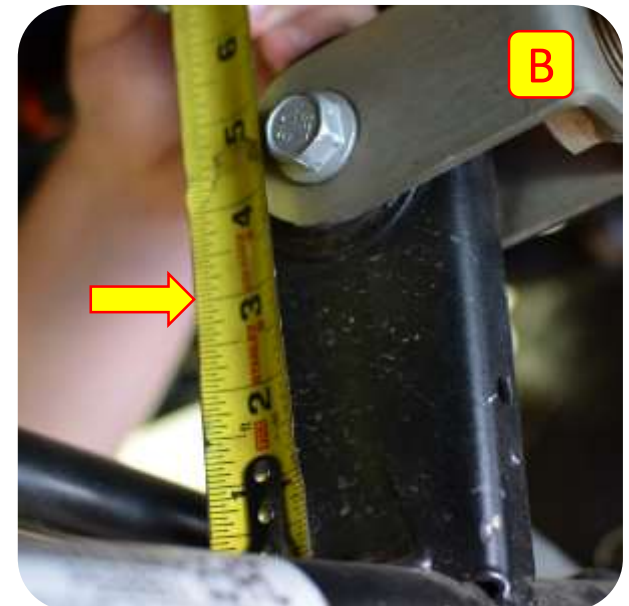

Section 3: FRONT SUSPENSION Installation Instructions



Step 2: Install Axle Bracket

Important Note: *This assembly when installed will have the open face of the gusset bracket directed to the front of the Jeep, the closed section will be facing the rearward direction (towards the control arm.)*

The billet insert that holds the Duroflex housing ring has a front and back side, the angled side of the billet piece will be facing to the front of the vehicle when placed in the tower gusset.



Section 3: FRONT SUSPENSION Installation Instructions



Step 2: Install Axle Bracket

- E. Insert Duroflex housing into billet insert and weld in place, the housing for the Duroflex joint should be inserted from the passenger side of the vehicle
- F. Weld the Duroflex housing around the housing lip to the billet insert.



Section 3: FRONT SUSPENSION Installation Instructions



Step 2: Install Axle Bracket

- G. Weld the fully welded assembly to the shortened axle bracket that was previously prepped.
- H. Allow the billet insert to cool fully before installing the Duroflex bushing

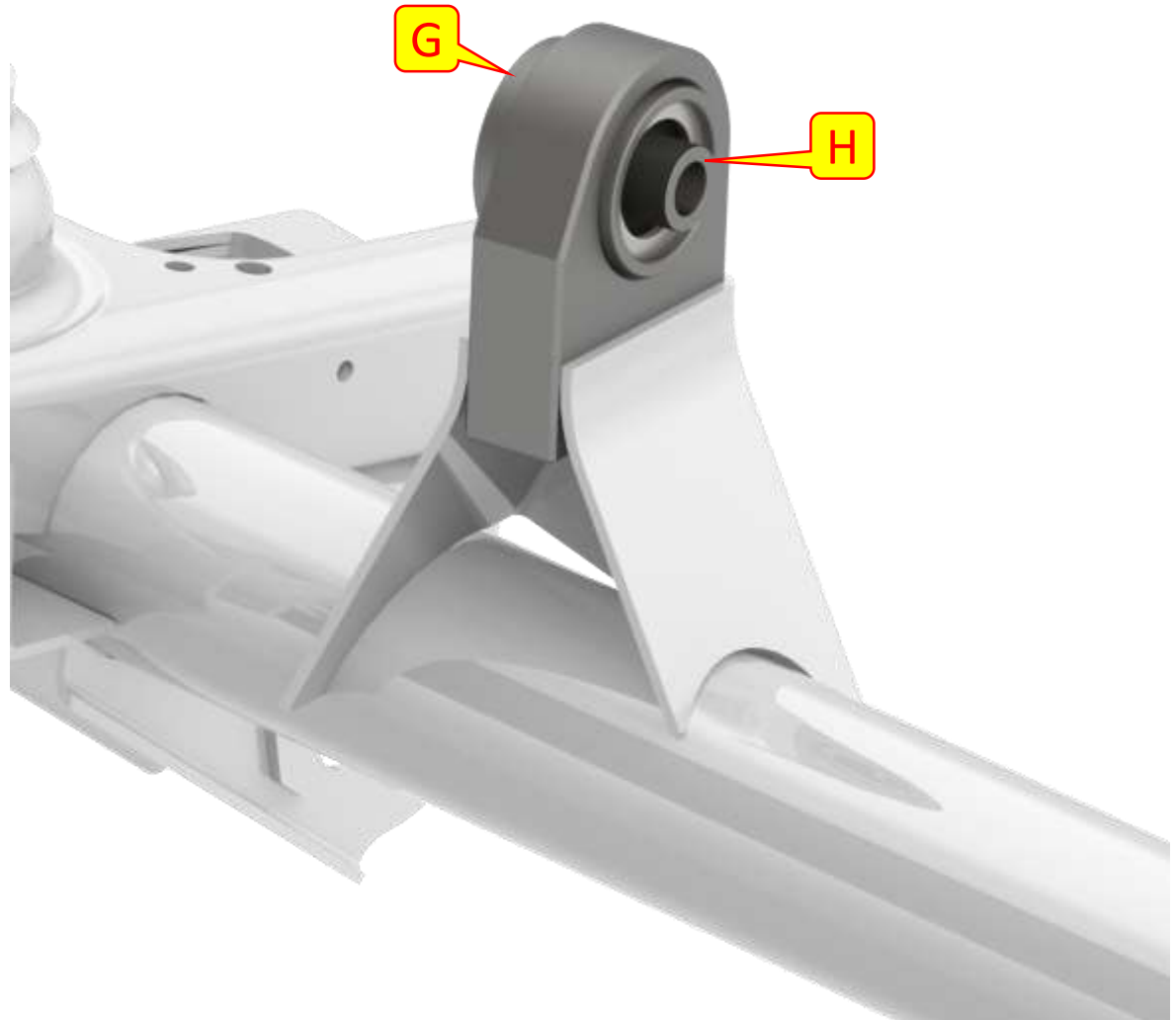

Note: *MetalCloak recommends that you paint all exposed metal to prevent rust.*

Section 3: FRONT SUSPENSION Installation Instructions



Step 3: Install Duroflex Bushing

Important Note: Heat from welding may damage the Duroflex bushing. Before assembly wait for all welds to cool.

- I. Install one retaining washer making sure the sharp edge of the ring is oriented outward from the center of the housing.
- J. Use the provided synthetic silicon/Teflon lubricant to lightly coat the outside of the Duroflex bushing paying special attention to partially filling the outside diameter grooves.
- K. Install Duroflex bushing.
- L. Install the second retaining washer.
- M. Install the snap ring on the end of the housing making sure the sharp edge of the ring is oriented outward from the center of the housing.
- N. Reinstall the upper front control arm.

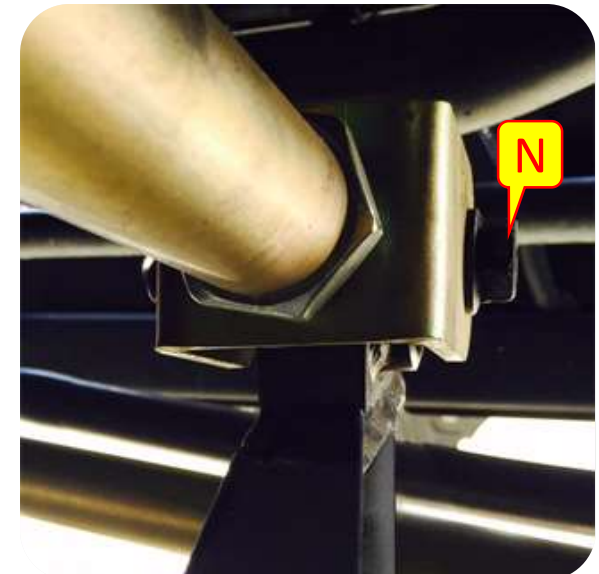
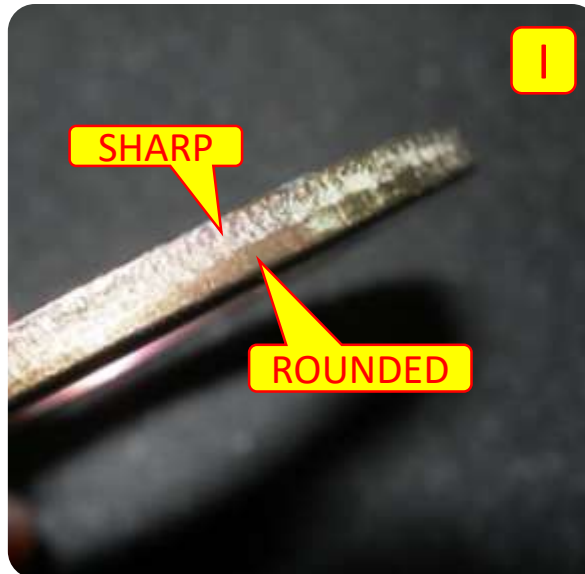
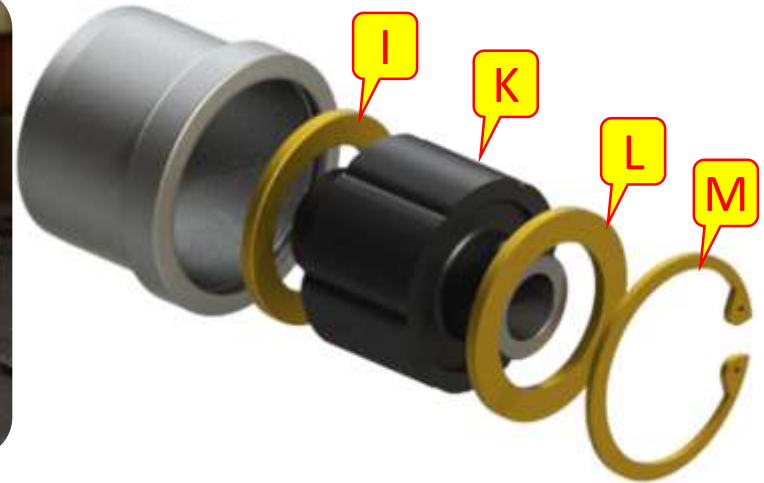

Section 3: FRONT SUSPENSION Installation Instructions



Step 4: Remove Stock Components

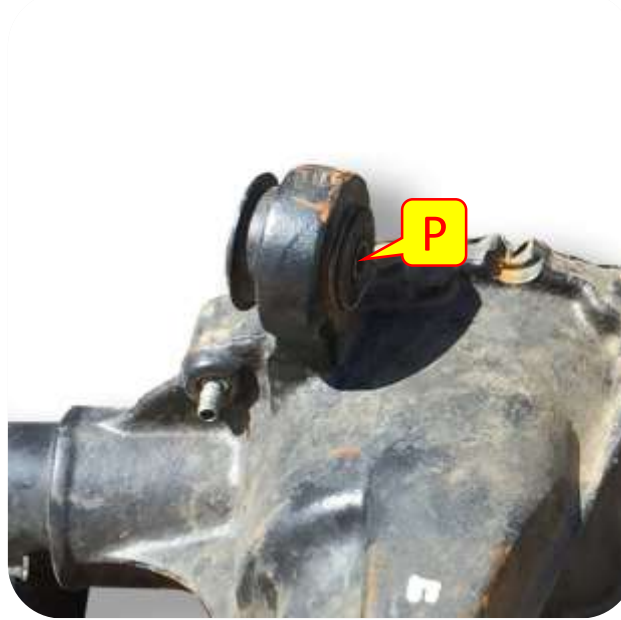
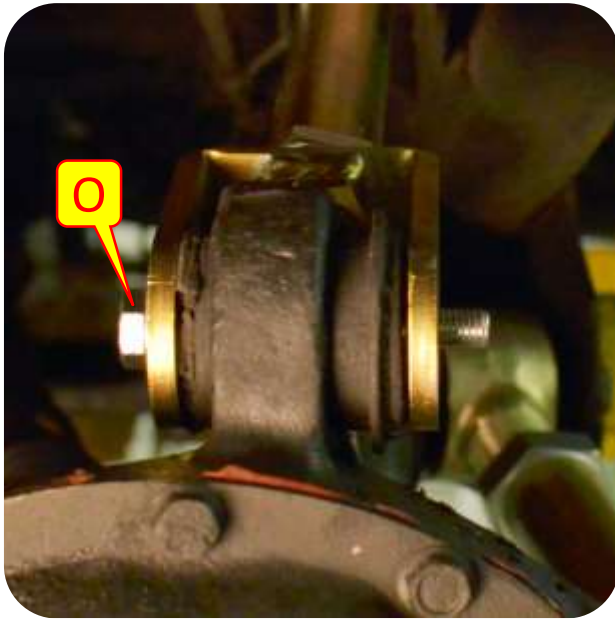

- O. Disconnect the driver's side upper control arm from the axle.
- P. Press out the factory clevis bushing.
- Q. Press in the provided bushing sleeve into the axle housing. Make sure the housing lip faces the driver's side of the Jeep.

Section 3: FRONT SUSPENSION Installation Instructions



Step 5: Install Duroflex Bushing

- R. Install one retaining washer making sure the sharp edge of the ring is oriented outward from the center of the housing.
- S. Use the provided synthetic silicon/Teflon lubricant to lightly coat the outside of the Duroflex bushing paying special attention to partially filling the outside diameter grooves.
- T. Install Duroflex bushing.
- U. Install the second retaining washer.
- V. Install the snap ring on the end of the housing making sure the sharp edge of the ring is oriented outward from the center of the housing.

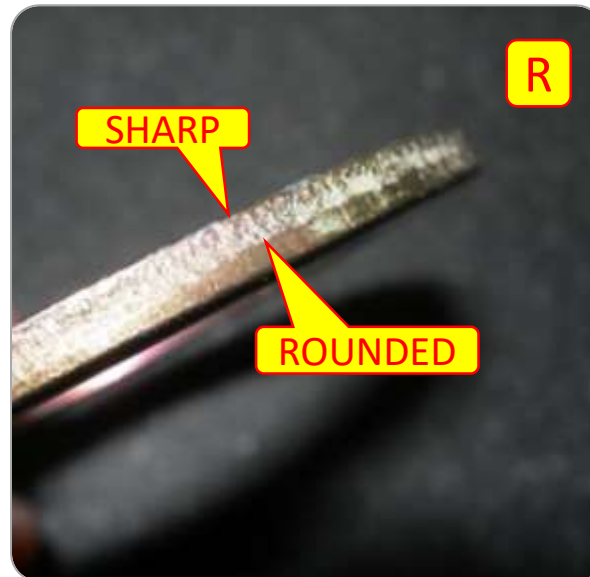
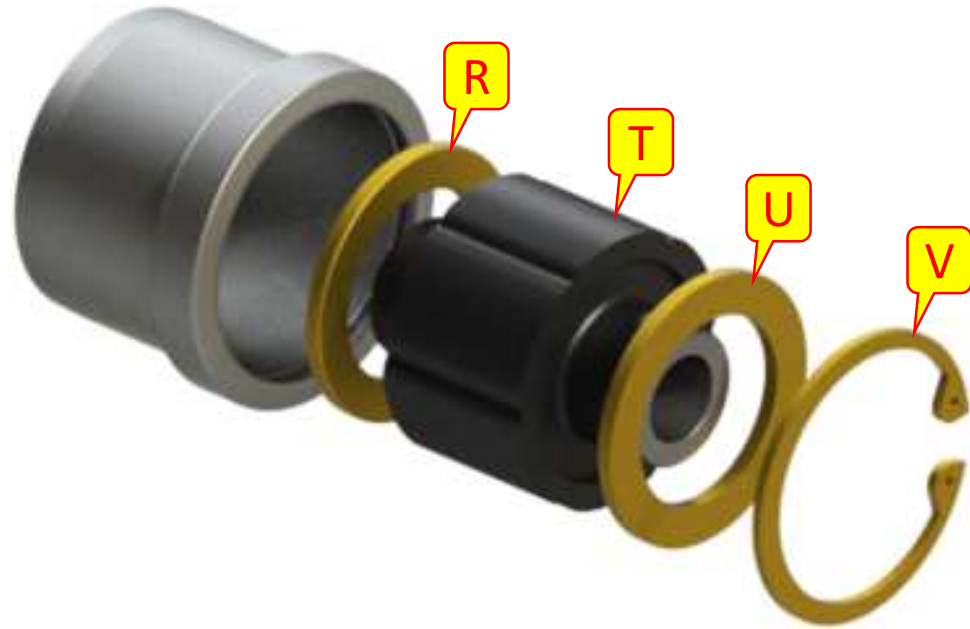

Section 3: FRONT SUSPENSION Installation Instructions



Step 6: Reinstall Components

- W. Reinstall the upper control arm.
- X. Reinstall the lower side of the track bar *(If disconnected)*.
- Y. Check and reset the caster if needed.

