



PRODUCT: JL Lower Front Outboard Shock Spacer Kit

REV: B | 03-15-2019 | II-7624

READ INSTRUCTIONS IN FULL BEFORE INSTALLATION.
QUESTIONS? CALL 916-631-8071 M-F 7:00 AM – 5:00 PM PST

The MetalCloak experience includes the ease of installation of our products. We design for most contingencies, but installation may be different based on different Jeep condition, configuration and/or year.

We are continually trying to improve our products and instructions – please help us by providing feedback and pictures if you find any part of the instructions that do not match your particular Jeep or are not easily understandable.

If you have any difficulties at all, please give us a call. Thank you and enjoy your MetalCloak Products!

IMPORTANT NOTE: We use Stainless Steel Hardware where possible. Therefore, a tube of Silver Anti-seize is provided and should be used on all bolts—only a small amount is needed.

WARRANTY INFORMATION: This article is sold without warranty expressed or implied. No warranty or representation is made as to this products ability to protect the user from injury or death. The user assumes that risk. The effectiveness, warranty and longevity of this equipment are directly related to the manner in which it is INSTALLED, USED and/or MAINTAINED. THE USER ASSUMES ALL RISK. By purchasing this product and opening the packaging, purchasers expressly acknowledge, understand and agree that they take, select and purchase these MetalCloak products from Armored Works, LLC, its affiliates and distributors and agents as is and with all faults. The entire risk as to the quality and performance of these MetalCloak products is with the purchaser. Working on your vehicle can be a dangerous activity. If you are unsure of what you are doing, please leave mechanical or safety critical work to a skilled mechanic. We take no responsibility for the incorrect use and/or installation of MetalCloak products.

Section 1: Tools & Notes on Installation

Tools Required: This list is the recommended tools for ease of installation. Other versions of the same tool can be used. For example, Allen Wrenches instead of Allen Drive Sockets.



Socket & Ratchet Wrench

14mm Socket/Wrench
18mm Socket/Wrench
19mm Socket/Wrench



3/8" Drill Bit
(3/8" Step Bit Recommended)

14mm Socket/Wrench
18mm Socket/Wrench
19mm Socket/Wrench



Drill
(Angle Drill Recommended)

HOW TO USE THIS GUIDE: The installation guide contains ALL steps for installation. Please read and follow the instructions in order of each page top to bottom, and left to right.

Jeep Model: Instructions may apply to multiple Jeep models, but are labeled separately where appropriate (i.e. TJ vs. LJ).

Options: Because of the number of component options we offer, these instructions may contain steps that will not match your particular configuration. You can skip these steps.

Images: Pictures are provided and parts are labeled throughout the instructions. Each text box contains guidance based on the pictures next to it. The text will refer to alphabetical labels (A, B, etc) found in the images.

Installation Notes: Terms may be used in the body of the instructions that you may not be familiar with, if you have any questions feel free to contact us at the number below, or email techhelp@metalcloak.com

QUESTIONS: Any questions or comments about the instructions? Call us at 916-631-8071 M-F 7:00 AM – 5:00 PM PST.

Section 2: Product Components

DC-0001 REV A

SHEET 1 OF 1

ITEM	PART NUMBER/DESCRIPTION	QTY.	BIN
1	WM-6218 SHOCK RELOCATION BRACKET, JL FRONT	1	
2	WM-6218-P SHOCK RELOCATION BRACKET, JL FRONT	1	
3	SS-1078 SPACER PIPE, .75ID X SCHD80 X 1.47L ALUM HK-7624	2	-
4	FM-12131 HHCS, M12-1.75 x 85L STL C10.9 ZINC	1	
5	FM-12132 TOPLOCK NUT, M12-1.75 X 12H STL C10 ZINC	2	-
6	FS-06053 SERRATED FLANGE LOCK NUT, 0.38-16 X 0.34H STL GF ZINC	2	C35
7	FS-06104 HHCS SERRATED FLANGE, 0.38-16 X 0.75L STL G5 ZINC	4	A26
8	FS-08023 WASHER, 0.53ID X 1.06OD X 0.10TH STL ZINC	4	B34
9	FS-08038 SERRATED FLANGE LOCK NUT, 0.5-13 X 0.45H STL GF ZINC	6	B6
10	FS-08195 HHCS, 0.5-13 X 2.5L STL G8 ZINC	2	A28

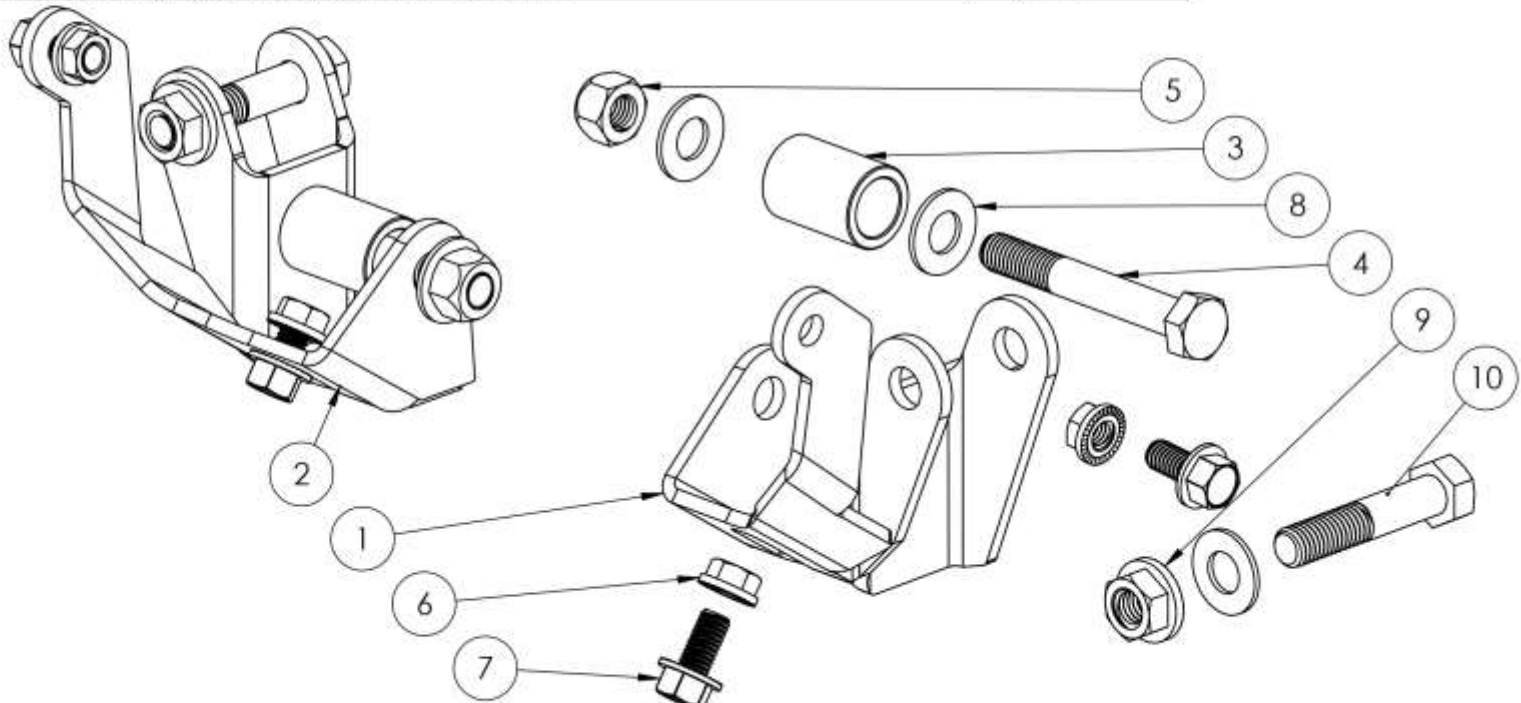

THE INFORMATION CONTAINED ON THIS DRAWING IS THE EXCLUSIVE PROPERTY OF ARMORED WORKS, LLC. UNAUTHORIZED REPRODUCTION IS PROHIBITED.
DO NOT SCALE DRAWING
MetalCloak
 A DIVISION OF ARMORED WORKS, LLC
PART NUMBER/DESCRIPTION
 7624 OUTBOARD SHOCK MOUNT KIT, JL FRONT LOWER

Section 3: Installation Instructions

Step 1: Remove Stock Components

Important Note: *If using stock wheels with factory backspacing the outboard shock mount is not recommended as it will interfere with the wheel.*

- A. Using a 18mm wrench and socket remove the bottom shock hardware and pull shock from stock shock bracket. **SAVE ALL HARDWARE.**
- B. Using a 10mm socket disconnect the brake line bracket from the coil perch.



Section 3: Installation Instructions

Step 2: Install Outboard Shock Spacer Kit

- C. Drill out the brake line bracket hole using a 3/8" drill bit or step bit.
- D. Drill out the hole located on the bottom of the stock shock mount using a 3/8" drill bit or step bit.
- E. Place the outboard spacer on the stock shock mount so it aligns with the pre existing holes.



Section 3: Installation Instructions

Step 2: Install Outboard Shock Spacer Kit

- F. Install the lower shock mount bolt hand tight.
- G. Install the provided bolt and nut into the brake line bracket mount location hand tight.
- H. Install the spacer and stock hardware into the stock location and tighten using a 18mm socket and wrench.
- I. Using a 14mm wrench and socket tighten the two remaining bolts.

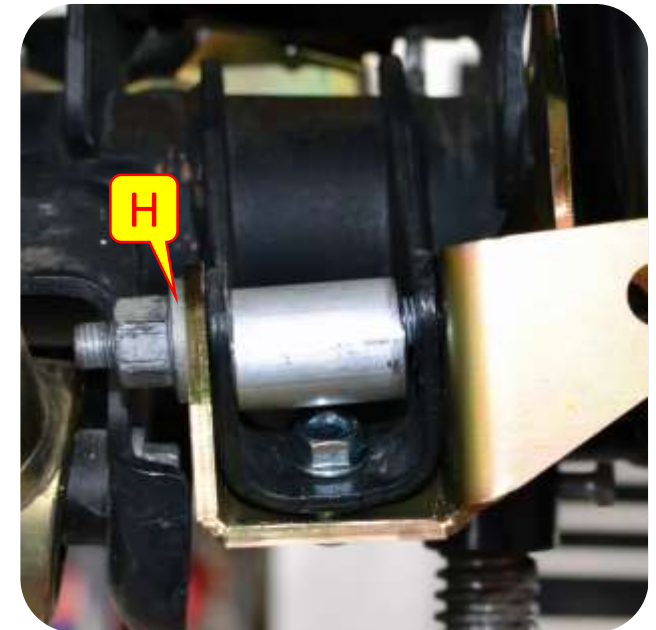
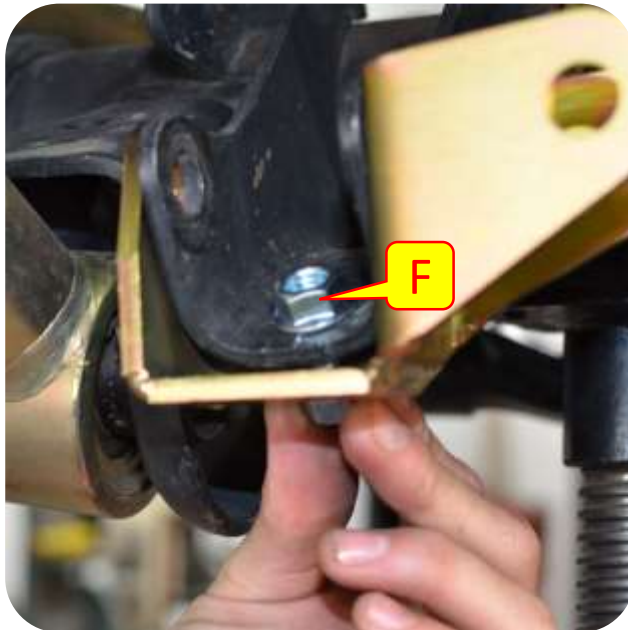

Section 3: Installation Instructions

Step 3: Install Shock

- J. Align the shock with the outboard shock mount.
- K. Install the shock with the provided 1/2" bolt and flange lock nut.
- L. Using a 19mm wrench and socket tighten the 1/2" bolt and flange lock nut.
- M. Secure the brake line bracket back on to the coil perch with a zip tie.

