



PRODUCT: RAM Front Track Bar Drop Bracket

REV: A | 06-27-2022 | II-8073

READ INSTRUCTIONS IN FULL BEFORE INSTALLATION.
QUESTIONS? CALL 916-631-8071 M-F 7:00 AM – 5:00 PM PST

The MetalCloak experience includes the ease of installation of our products. We design for most contingencies, but installation may be different based on different vehicle condition, configuration and/or year.

We are continually trying to improve our products and instructions – please help us by providing feedback and pictures if you find any part of the instructions that do not match your particular vehicle or are not easily understandable.

If you have any difficulties at all, please give us a call. Thank you and enjoy your MetalCloak Products!

IMPORTANT NOTE: We use Stainless Steel Hardware where possible. Therefore, a tube of Silver Anti-seize is provided and should be used on all bolts—only a small amount is needed.

WARRANTY INFORMATION: This article is sold without warranty expressed or implied. No warranty or representation is made as to this products ability to protect the user from injury or death. The user assumes that risk. The effectiveness, warranty and longevity of this equipment are directly related to the manner in which it is INSTALLED, USED and/or MAINTAINED. THE USER ASSUMES ALL RISK. By purchasing this product and opening the packaging, purchasers expressly acknowledge, understand and agree that they take, select and purchase these MetalCloak products from Armored Works, LLC, its affiliates and distributors and agents as is and with all faults. The entire risk as to the quality and performance of these MetalCloak products is with the purchaser. Working on your vehicle can be a dangerous activity. If you are unsure of what you are doing, please leave mechanical or safety critical work to a skilled mechanic. We take no responsibility for the incorrect use and/or installation of MetalCloak products.

Section 1: Tools & Notes on Installation



Tools Required: This list is the recommended tools for ease of installation. Other versions of the same tool can be used. For example, Allen Wrenches instead of Allen Drive Sockets.



Socket & Ratchet Wrench

21mm Socket
27mm Socket



27mm wrench

HOW TO USE THIS GUIDE: The installation guide contains ALL steps for installation. Please read and follow the instructions in order of each page top to bottom and left to right.

Ram Model: Instructions may apply to multiple truck models but are labeled separately where appropriate.

Options: Because of the number of component options we offer, these instructions may contain steps that will not match your particular configuration. You can skip these steps.

Images: Pictures are provided, and parts are labeled throughout the instructions. Each text box contains guidance based on the pictures next to it. The text will refer to alphabetical labels (A, B, etc.) found in the images.

Installation Notes: Terms may be used in the body of the instructions that you may not be familiar with, if you have any questions feel free to contact us at the number below, or email techhelp@metalcloak.com

QUESTIONS: Any questions or comments about the instructions? Call us at 916-631-8071 M-F 7:00 AM – 5:00 PM PST.

Section 2: Product Components

DC-0001 Rev B

SHEET 1 OF 1

ITEM	PART NUMBER/DESCRIPTION	QTY.
1	WM-8108 WELDMENT, FRONT TRACK BAR DROP BRACKET, RAM 2500 2019+	1

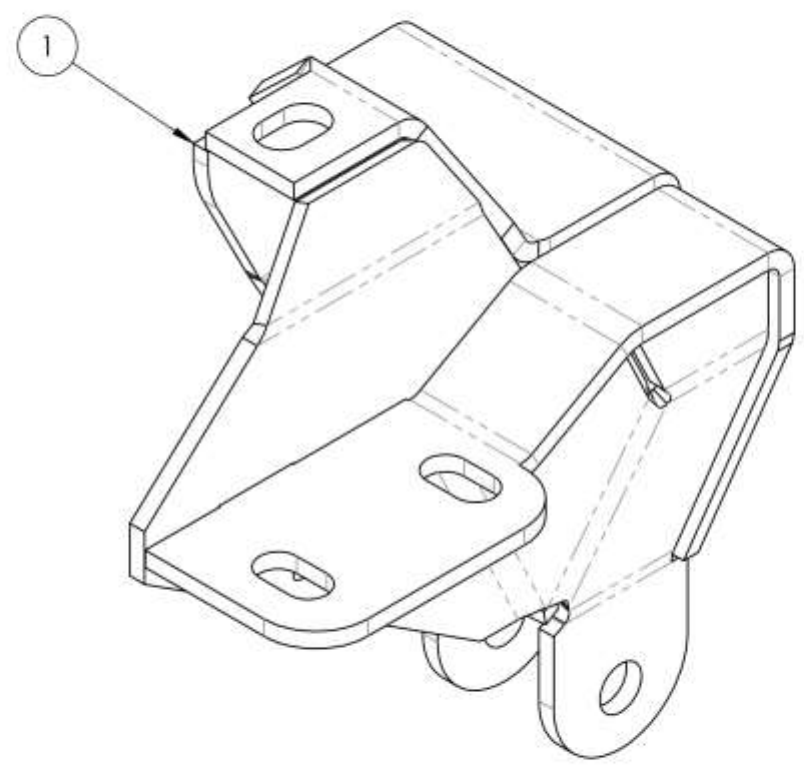

<p>THE INFORMATION CONTAINED ON THIS DRAWING IS THE EXCLUSIVE PROPERTY OF ARMORED WORKS, LLC. UNAUTHORIZED REPRODUCTION IS PROHIBITED.</p> <p>DO NOT SCALE DRAWING</p>		 A DIVISION OF ARMORED WORKS, LLC
<p>PART NUMBER/DESCRIPTION 8073 FRONT TRACK BAR DROP BRACKET, RAM 2500, 2019+</p>		

Section 3: Installation Instructions

Step 1: Preparation for the Front Track Bar Drop Bracket

- A. Using a 27MM socket on a breaker bar or impact wrench, remove the frame side track bar mounting bolt (*A 27MM wrench should be used to prevent the nut from rotating while removing*).
- B. Drop the track bar out of the stock bracket.
- C. Using a 21MM socket, remove the 5 bolts that hold the stock track bar bracket to the frame (*2 bolts on the side of the frame and 3 bolts on the bottom*). This will free the bracket allowing it to be removed.

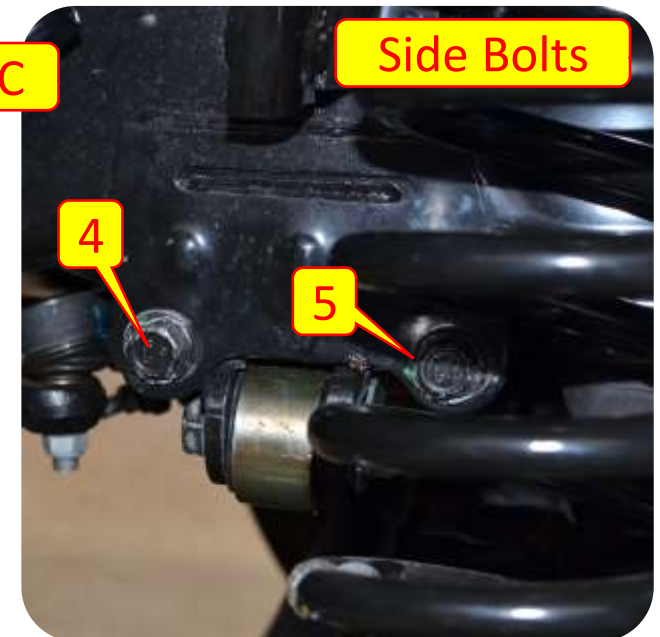
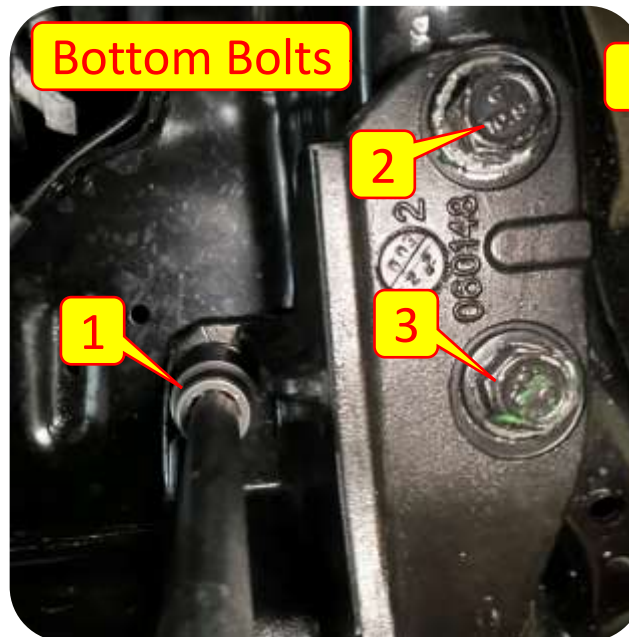

Section 3: Installation Instructions



Step 2: Install Front Track Bar Drop Bracket

- D. Put the MetalCloak track bar drop bracket in place and reinstall the 5 factory bolts into the new bracket.
- E. Reinstall the frame side track bar end into the MetalCloak drop bracket and reinsert the track bar mounting bolt through the new bracket and track bar end. If alignment is difficult, turning the steering wheel can aid in shifting the axle and track bar into alignment.
- F. Torque bolts to factory specifications.

