



PRODUCT: Game Changer Suspension, 6Pak Edition

REV: K | 04-01-2024 | II-A1245/A1255

READ INSTRUCTIONS IN FULL BEFORE INSTALLATION.
QUESTIONS? CALL 916-631-8071 M-F 7:00 AM – 5:00 PM PST

The MetalCloak experience includes the ease of installation of our products. We design for most contingencies, but installation may be different based on different Jeep condition, configuration and/or year.

We are continually trying to improve our products and instructions – please help us by providing feedback and pictures if you find any part of the instructions that do not match your particular Jeep or are not easily understandable.

If you have any difficulties at all, please give us a call. Thank you and enjoy your MetalCloak Products!

IMPORTANT NOTE: We use Stainless Steel Hardware where possible. Therefore, a tube of Silver Anti-seize is provided and should be used on all bolts—only a small amount is needed.

WARRANTY INFORMATION: This article is sold without warranty expressed or implied. No warranty or representation is made as to this products ability to protect the user from injury or death. The user assumes that risk. The effectiveness, warranty and longevity of this equipment are directly related to the manner in which it is INSTALLED, USED and/or MAINTAINED. THE USER ASSUMES ALL RISK. By purchasing this product and opening the packaging, purchasers expressly acknowledge, understand and agree that they take, select and purchase these MetalCloak products from Armored Works, LLC, its affiliates and distributors and agents as is and with all faults. The entire risk as to the quality and performance of these MetalCloak products is with the purchaser. Working on your vehicle can be a dangerous activity. If you are unsure of what you are doing, please leave mechanical or safety critical work to a skilled mechanic. We take no responsibility for the incorrect use and/or installation of MetalCloak products.

Section 1: Tools & Notes on Installation

Tools Required: This list is the recommended tools for ease of installation. Other versions of the same tool can be used. For example, Allen Wrenches instead of Allen Drive Sockets. Be sure to use metric on metric and SAE on SAE.



Socket & Ratchet Wrench

Set of SAE & Metric Sockets & Wrenches



Metal Head Hammer

Metric Hex Drive Sockets and/or Hex (Allen) Wrenches



10" Socket Extension

3/8" Flare Nut Wrench (10mm will work) for Brake Lines



Cut-Off Disc and Grinder
(Optional)

Electric Drill
1/4", 1/2", 7/16", L, 9/16", 7/8" Drill Bits



HOW TO USE THIS GUIDE: The installation guide contains ALL steps for installation. Please read and follow the instructions in order of each page top to bottom, and left to right.

Jeep Model: Instructions may apply to multiple Jeep models, but are labeled separately where appropriate (i.e. TJ vs. LJ).

Options: Because of the number of component options we offer, these instructions may contain steps that will not match your particular configuration. You can skip these steps.

Images: Pictures are provided and parts are labeled throughout the instructions. Each text box contains guidance based on the pictures next to it. The text will refer to alphabetical labels (A, B, etc.) found in the images.

Installation Notes: Terms may be used in the body of the instructions that you may not be familiar with, if you have any questions feel free to contact us at the number below, or email techhelp@metalcloak.com

QUESTIONS: Any questions or comments about the instructions? Call us at 916-631-8071 M-F 7:00 AM – 5:00 PM PST.

Section 3: Installation Instructions



Important Note: MetalCloak does not recommend powder coating your True Dual Rate Coils. The baking process in powder coating can, in some cases, cause the metallurgical properties of the coils to be changed, resulting in the loss of the lift properties of the coils. As such, the process of powder coating the coils will void any warranty stated or implied in relation to the coils.

Important Note: To install lift components you will need to fully 'droop' your suspension in the front and rear (not at the same time). We strongly recommend that the vehicle be placed on an automotive lift and that all appropriate safety precautions be taken to secure the vehicle while it is off the ground. Always use the necessary axle stands (or equivalent) to support the axle when the suspension components are disconnected for safety, and to ensure the integrity of your suspension system during the installation process.

Important Note: All shocks are marked on the shock plate to identify the shocks corresponding location.

JKF – Front Shocks

JKRD – Rear Driver Side Shock

JKRP – Rear Passenger Side Shock



Section 3: Installation Instructions

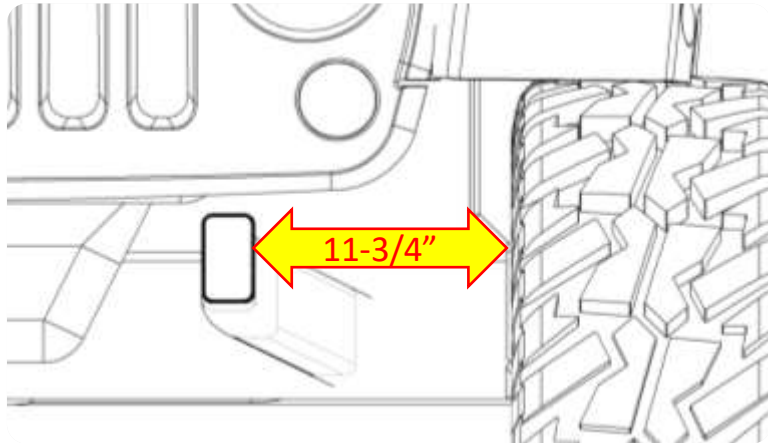

Important Note: To prevent tires from rubbing the shocks at full turn and flex, a clearance of 11-3/4" between inner wall of the tire and the outside of the frame rail is recommended. Wheel backspacing, wheel spacers, axle width and tire width can effect this value. We recommend a wheel backspacing of less than or equal to 4.0" for most common vehicle builds.

Step 1: Remove Stock Components

- A. Disconnect front sway bar links.
- B. Watch the ABS and brake lines as the axle drops! Unbolt the brake line bracket from the frame and axle in case the lines are stretched while working.
- C. Remove the front track bar, save hardware for re-use.
- D. Remove sway bar end links, save the bottom bolt for use later.

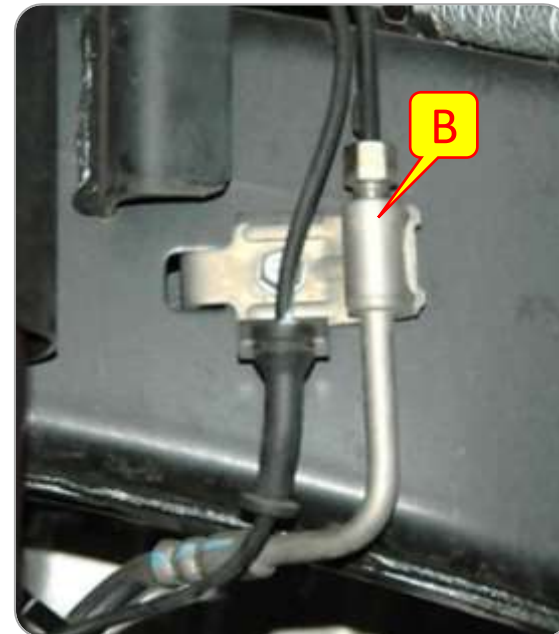

Section 3: Installation Instructions

Step 1: Remove Stock Components

- E. Use a 16MM Wrench on top and bottom to remove the stock nut on top of the upper shock mount tower.
- F. Use a 18MM Socket and Wrench to remove the stock nut and bolt from the lower shock mount bracket located on the axle.
- G. Remove stock springs, and any spacers that have been used if vehicle has been previously lifted. The rubber isolator will be re-used.



Step 2: Swap Front Control Arms

		FRONT CONTROL ARMS		REAR CONTROL ARMS	
CASTOR ANGLE		UPPER	LOWER	UPPER	LOWER
FACTORY CONTROL ARMS	STOCK	22 5/8"	18 3/4"	19 3/4"	17 7/16"
METALCLOAK 2.5"/3.5" LIFT	5 DEGREES	23 1/16"	18 3/4"	20 7/16"	18 7/16"

Section 3: Installation Instructions

Step 2: Swap Front Control Arms

- H. Use an 18mm Socket & Wrench to remove the stock bolts from the upper control arms.
- I. The exhaust on the passenger side of some models interferes with removal of the upper bolt. Cut the stock bolt and replace it with the Flange Hex Head Bolt and Hex Flange Nut provided, install bolt from the outside of frame and the nut inside the frame [H1].
- J. Use a 21mm Socket and Wrench to remove the stock hardware and control arms; re-use this hardware to install the MetalCloak Front Lower Control Arms.
- K. Install the Control Arms so that the short bend (with the Lock Nut) is in the rear, and the arm angles INBOARD to provide tire turning clearance.

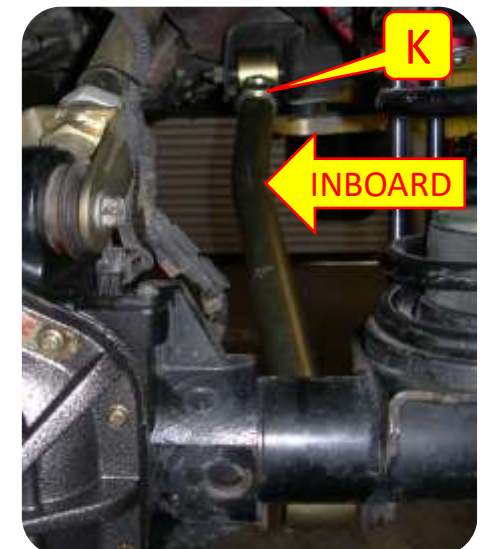
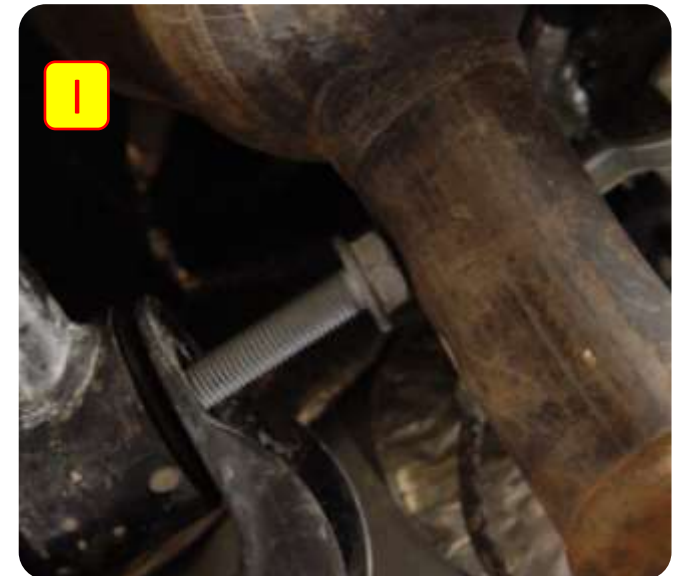
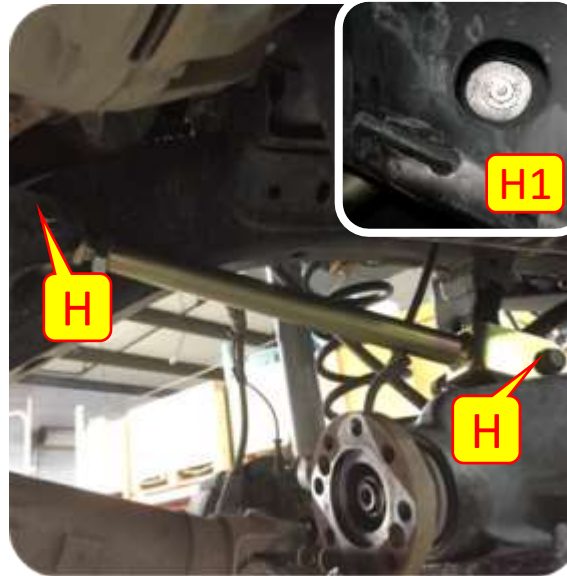



Section 3: Installation Instructions



Coil Isolator Information Guide

Important Note: MetalCloak's suspension systems include a unique coil design that utilizes upper isolators to position the coil. The following table will help you identify where to install the isolators included with your kit. You must remove the stock isolators before installing the provided coil isolators. If you have any questions give us a call at 916-631-8071.

Coil Isolator Jeep Locations		
Isolator Type	Jeep Model	Installation Locations
Tall Isolator 	JL Wrangler 3.6L Non-E Torque	Upper Front Passenger
	JL Wrangler 2.0T E-Torque	Upper Front Driver & Passenger
	JL Wrangler 4xE	Upper Front Driver & Passenger
	JL Wrangler Diesel	Upper Front Driver & Passenger
	JT Gladiator Diesel	Upper Front Driver & Passenger
Short Isolator 	JK Wrangler (All Models)	Upper Front Driver & Passenger
	JL Wrangler 3.6L Non-E Torque	Upper Front Driver
	JL Wrangler 3.6L E-Torque	Upper Front Driver & Passenger
	JL Wrangler Turbo	Upper Front Driver & Passenger
	JL Gladiator 3.6L Motor	Upper Front Driver & Passenger
Rear Isolator 	JL Wrangler 3.6L Non-E Torque	Upper Rear Passenger
	JL Wrangler 4xE	Upper Front Driver & Passenger

Section 3: Installation Instructions

Step 3: Bump Stops and Coils

- L. Droop your suspension to gain access to the spring perch. Be sure to watch the ABS lines so they do not get over extended and break.
- M. Center a Bump Stop Disk on the top of the spring perch and mark the center of the hole.
- N. Drill a hole at the marked location. You can start your hole with a smaller drill bit and work your way up to a 1/2".



Section 3: Installation Instructions

Step 3: Bump Stops and Coils

- O. Select the appropriate Screw length so that the threads stick out of the bottom Disks approximately $3/4"$. Assemble your bump stops by feeding the $1/2"$ Countersunk Screw through the Cover Plate, and then threading through the Bump Stop Disks. The center hole in the Disk is intentionally small to create the most rigid assembly possible after installation.
- P. Place the assembled Bump Stop inside the spring before re-installing. Re-install the spring and place the end of the $1/2"$ Screw in the drilled hole.
- Q. The $1/2"$ Screw is backed by a $1/2"$ Flanged Nylon Lock Nut. Install the nut and tighten the hardware using a $5/16"$ Hex Key Socket or Allen Wrench and a $3/4"$ Wrench. Tighten until everything is tight; the hardware will not bottom out, but instead will begin to compress the Disks.
- R. Repeat all steps for other side, and then re-install all other suspension components.

Note: *The bump stops may also be assembled inside the coil springs after they are installed.*

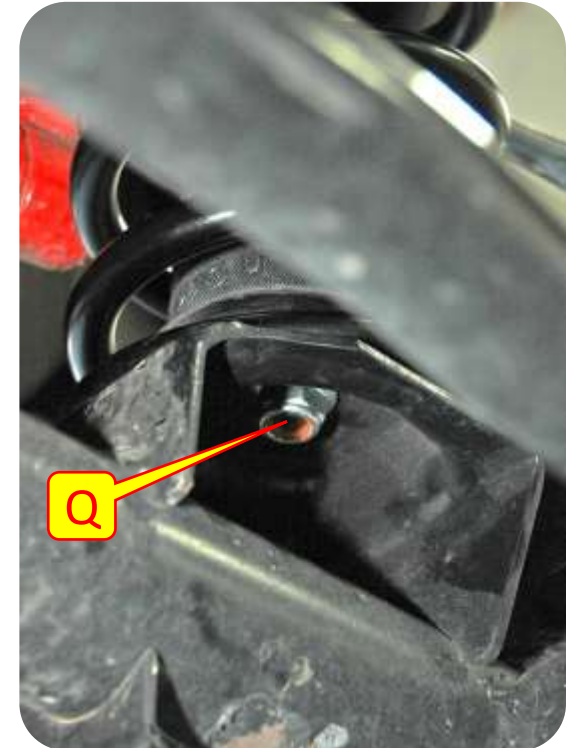

Section 3: Installation Instructions



Step 3: Bump Stops and Coils

- T. If the axle does not “droop” enough to allow the coil to be put in place a coil compressor can be used to compress the coil to allow fitment.
- U. Install Front Dual Rate Coils with the tightly wound coils oriented upward.
- V. Slip the bottom of the coil onto the coil base on the axle.



Section 3: Front Shock Installation Instructions

Step 4: Shock & Shock Bracket Installation

- W. Align the top 2 holes of the Upper Shock Mount Bracket to the stock holes of the shock mount tower. Install the provided 1/2"-13 Hex Cap Screws with a 1/2" Washer under the head, backed by 1/2" Flange Lock Nuts; finger-tighten the hardware.
- X. Center the Bracket in the shock mount tower. Mark the bottom hole, drill a 1/2" hole in this location, and install the third 1/2" Screw in this hole. Fully tighten all 1/2" hardware.
- Y. Install the bushing end (*top*) of the 6Pak shock and the bottom of the shock in the stock mount.
- Z. The axle side shock mounts into bracket with aluminum spacers pushing the shock outboard; big spacer on the inboard side and short spacer on the outboard side.

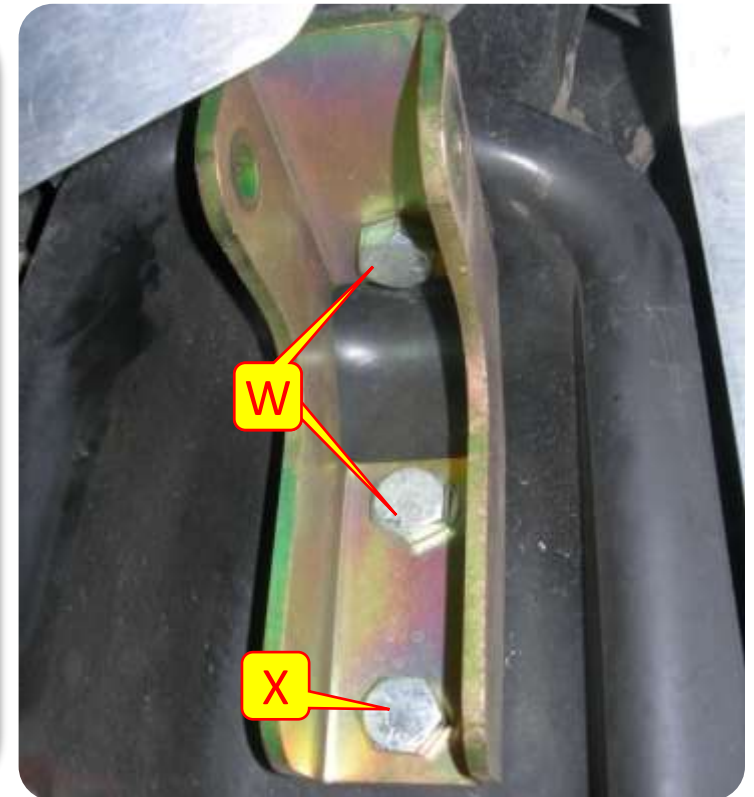

Note: The 6-Pak Shock Reservoir Tubes (RED) should point away from the vehicle, perpendicular to the frame of the Jeep.

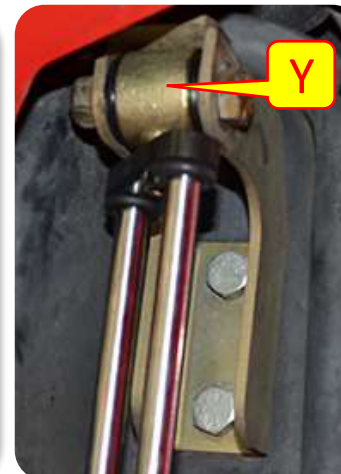

Section 3: Installation Instructions

Step 5: Install Front Brake Lines

Note: Place a drain pan/fluid catch under caliper; fluid will leak out when removing brake lines.

- AA. Use a 15mm Socket to remove the 'banjo' bolt from the brake calipers. Dis-guard the old copper washers. You will want an oil drain pan to catch the brake fluid.
- BB. Use a 12mm Wrench to unscrew the stock brake line from the frame bracket.
- CC. Unclip the ABS line from the brake line (all the way down) and use a 10mm Socket to remove the bolt holding the stock bracket. Remove the frame clip and brake line discard.

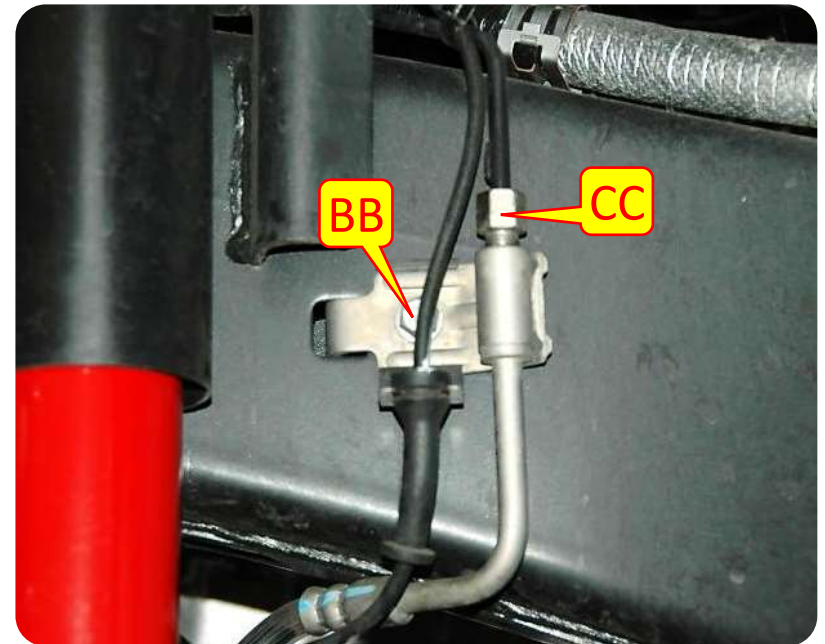
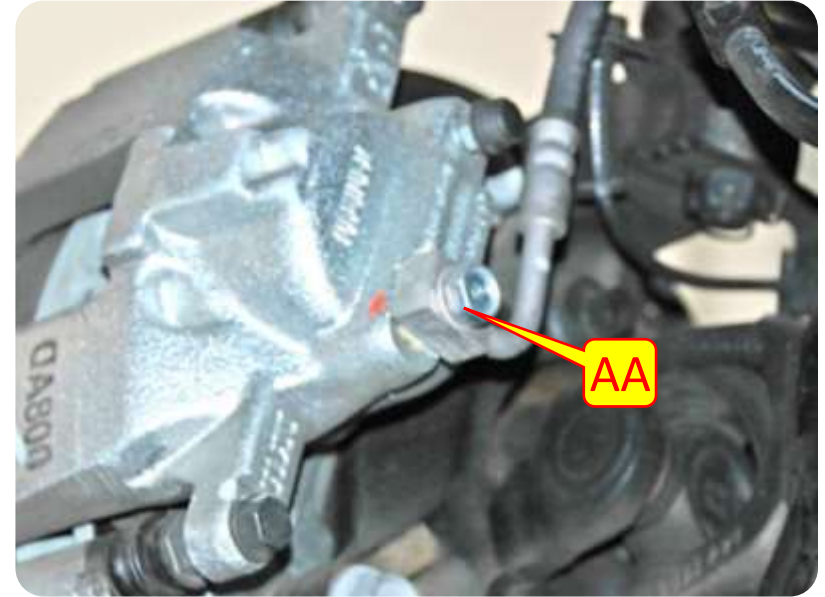

Section 3: Installation Instructions

Step 6: Install Front Brake Line

- DD. Place the L-bracket on the frame in the factory location using the factory hardware.
- EE. Install the 24-1/2" Brake Line through the bracket.
- FF. Screw the stock line into the new Brake Line and tighten using a 12mm and 17mm Wrench.
- GG. Install the provided Spring Clip to retain the Brake Line in the Bracket. You may need a hammer to lightly tap this clip into place.
- HH. Use a 1/2" Socket to install the 5/16"-18 Hex Head Self-Tapping Screw. Do not fully tighten.
- II. Feed the banjo bolt through the square end of the brake line. Use the provided brass washers on both sides of the brake line as shown.
- JJ. Re-install the banjo bolt into the brake caliper.
- KK. Zip-tie the ABS lines to the new brake lines.

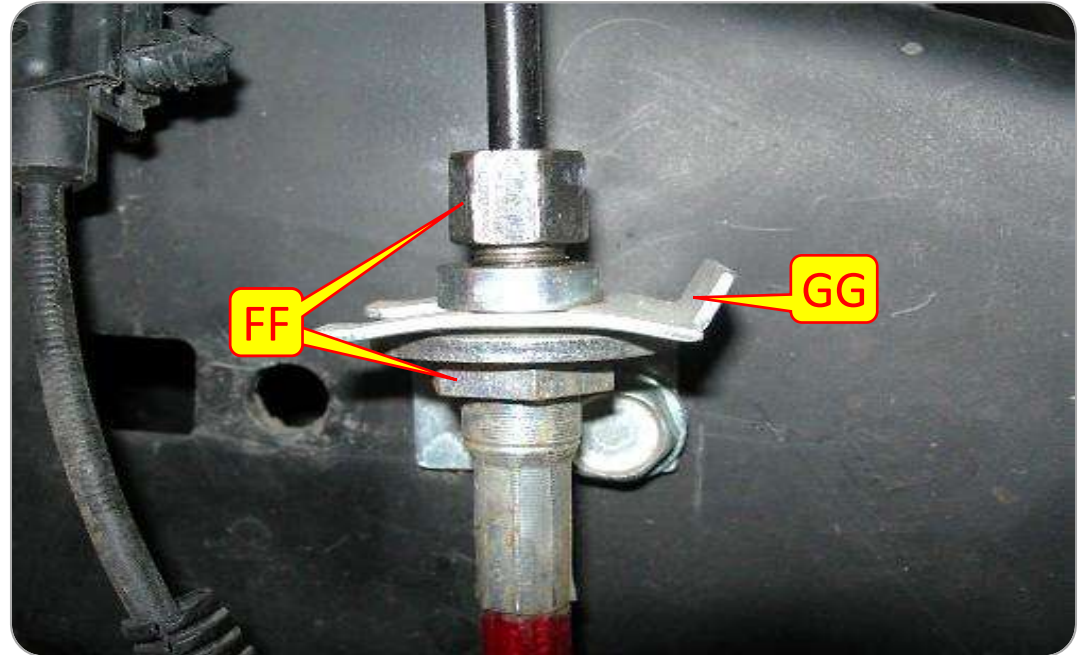

Section 3: Installation Instructions

Step 7: Install Drag Link Flip Kit

LL. Remove factory drag link from the steering pitman arm and the axle.

MM. Disconnect the axle mount side of the steering stabilizer (*If you have an aftermarket steering stabilizer mount, disconnect the mount*).

NN. Place the Flip Kit Mount over the top of the Axle

OO. Hand Tighten U-Bolt.

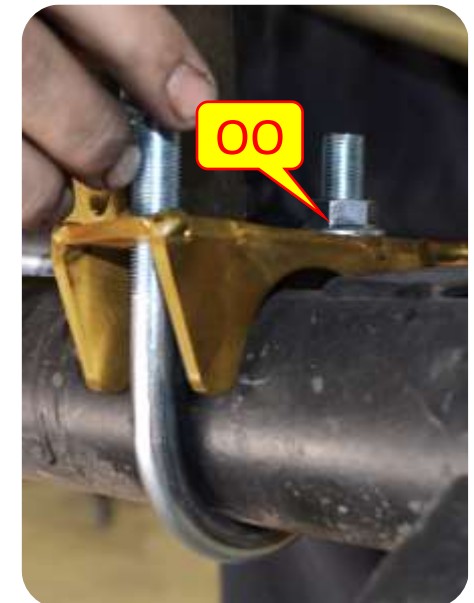
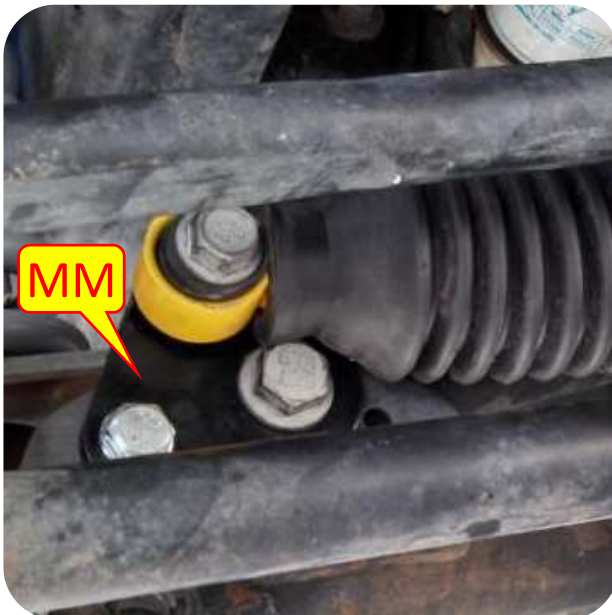

Section 3: Installation Instructions

Step 7: Install Drag Link Flip Kit

PP. Insert the bottom bolt spacer. It will go into the factory trac bar location

QQ. Using a 10mm Allen Socket and a 22mm wrench install the bottom bolt.

RR. Adjust Track Bar. As a starting point you can start out at 32 3/4". The adjustment end will go into the axle bracket, this end will also go in once the vehicle is on the ground.

SS. Install track bar using a 14mm socket and a 22mm wrench.

TT. Tighten the U-bolt nuts using a 19mm socket.

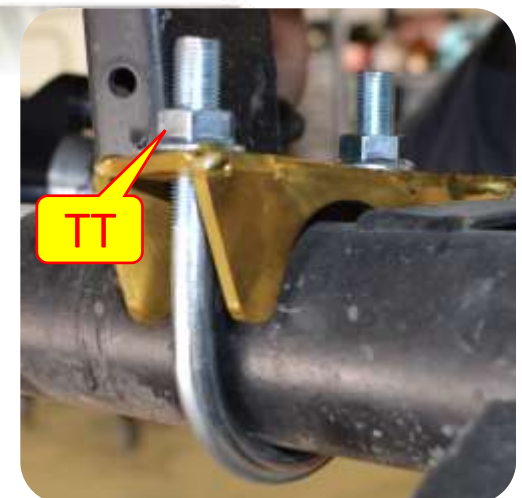
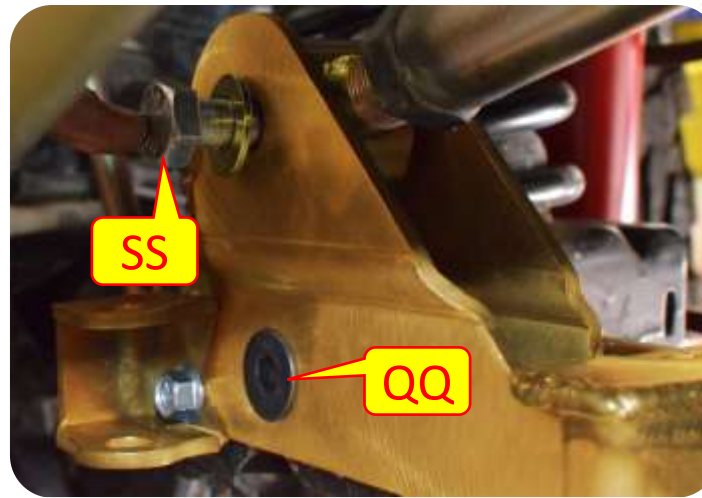
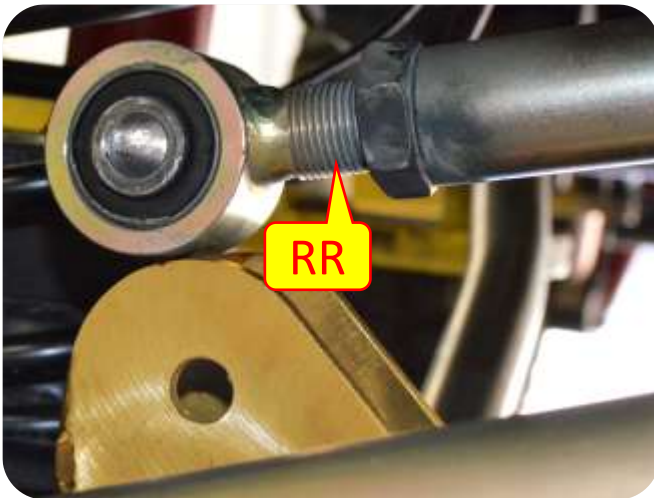
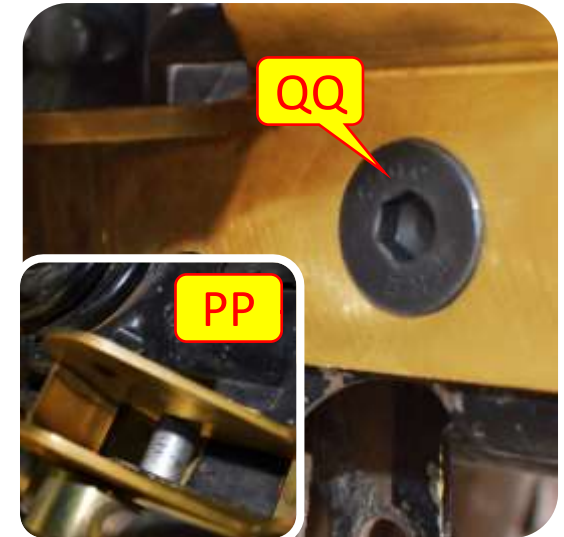

Note: *It is helpful to have someone push the vehicle to the driver or passenger side to help align the hole; if you don't have an extra pair of hands, you can use a ratchet strap on the frame/axle to pull the frame in the desired direction. Check to ensure the axle is centered once the bolt is in place. If not then remove the bolt, adjust the Track Bar length, replace the bolt, and re-check axle centeredness. Repeat until the axle is as close to center.*

Section 3: Installation Instructions

Step 7: Install Drag Link Flip Kit

UU. Install the steering stabilizer mount bolt and nut using a 9/16" wrench and socket (*insert the nut between the original steering stabilizer mount location*).

VV. Using a 7/8" drill bit drill out the drag link knuckle.

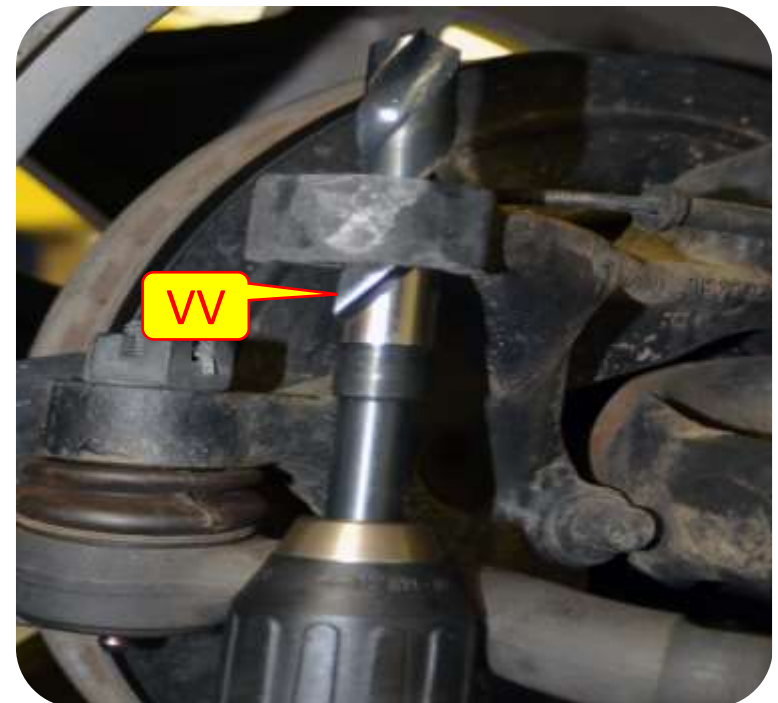
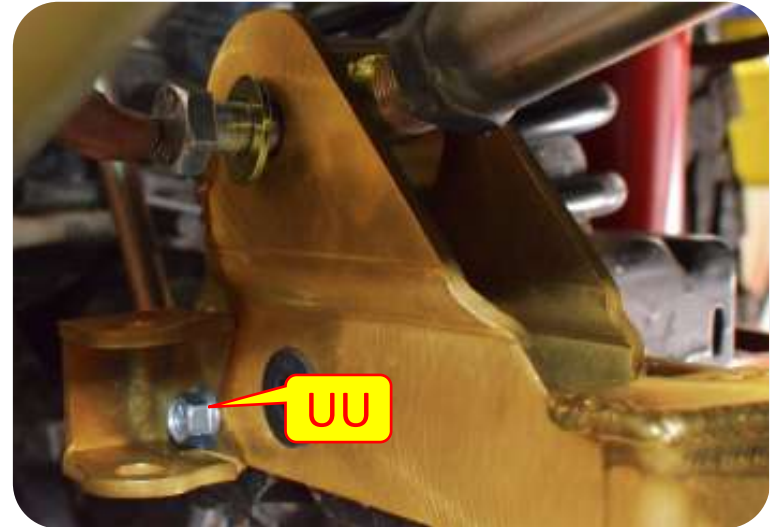

Section 3: Installation Instructions

Step 7: Install Drag Link Flip Kit



WW. Insert spacer into drilled out hole.

XX. Install new drag link into the knuckle and the steering box pitman arm.

YY. Tighten down drag link nut using an adjustable wrench

ZZ. Install cotter pin

AAA. Install the steering stabilizer into the steering stabilizer mount (*Install the bolt with the nut on top and tighten with a 19mm socket and wrench*).

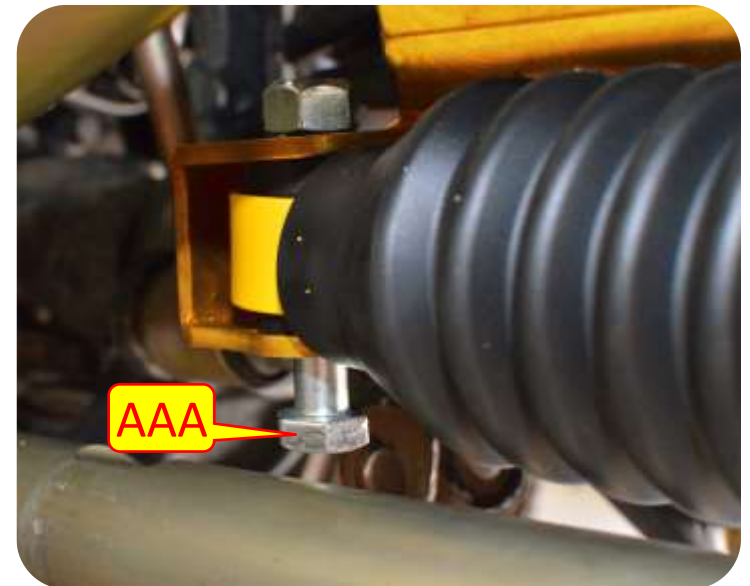
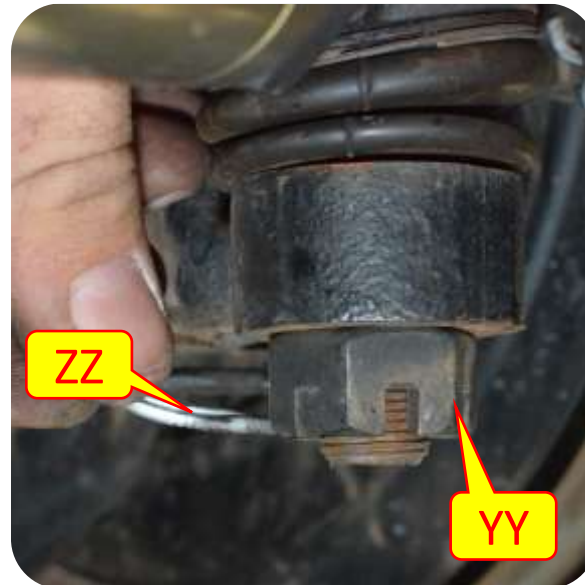

Section 3: Installation Instructions



Step 8: Install JK Front Track Bar

BBB. The fixed end of the MetalCloak JK Front Track Bar goes in the stock frame bracket. The clearance bends should point toward the front bumper, up and away from the differential cover. Re-use the stock hardware, and only hand tighten the hardware for now (you will fully tighten everything at the end).

CCC. The adjustable end of the Track Bar goes into the stock bracket on the axle, again re-using the stock hardware. With the full weight of the vehicle on the springs, push the bolt through the bracket and the Track Bar joint.

DDD. Fully tighten the stock hardware on both ends of the Track Bar, and then tighten the Jam Nut on the Track Bar.

EEE. MetalCloak **STRONGLY RECOMMENDS** having your alignment checked by a professional after changing any suspension components.

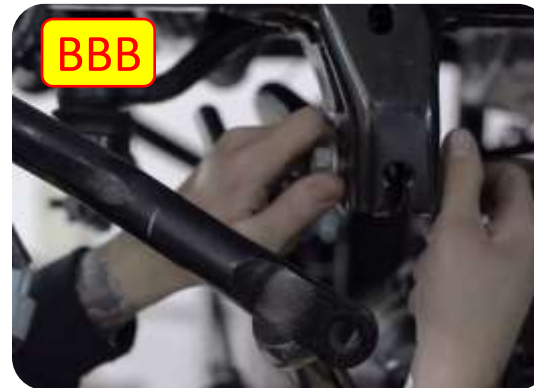

Note: It is helpful to have someone push the vehicle to the driver or passenger side to help align the hole; if you don't have an extra pair of hands, you can use a ratchet strap on the frame/axle to pull the frame in the desired direction. Check to ensure the axle is centered once the bolt is in place. If not then remove the bolt, adjust the Track Bar length, replace the bolt, and re-check axle centeredness. Repeat until the axle is as close to center.

Section 3: Installation Instructions

Step 9: Install Sway Bar Links

FFF. Install the lower quick disconnect pin in the stock location. Point the pin toward the center of the vehicle, backed by the provided $\frac{1}{2}$ "-13 hardware. A screwdriver through the hole on the end of the pin is helpful while tightening the nut with a $\frac{3}{4}$ " wrench.

Important Note:
MetalCloak recommends using red Loctite on each of the upper spindles of the sway bar end links.

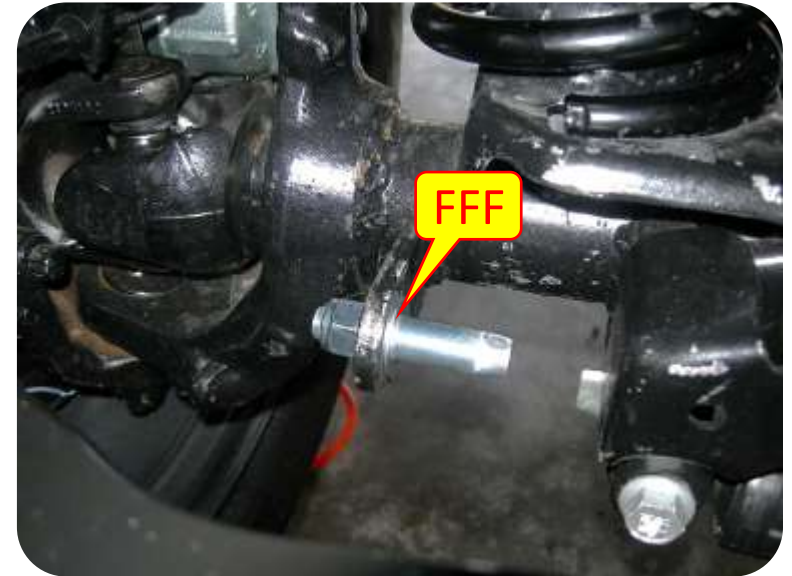

GGG. Assemble the sway bar link by threading a jam nut onto the lower link.

HHH. Now thread the link into the ball joint. Set the length to 12.25". Do not tighten Jam nut yet.

III. Install the ball joint on the outside of the sway bar end. You will need a thin $\frac{9}{16}$ " box end wrench to keep the ball joint from turning while you tighten the nut with a $\frac{5}{8}$ " wrench.



Section 3: Installation Instructions

Step 9: Install Sway Bar Links

JJJ. Installed lower rubber bushing on the quick disconnect pin.

KKK. Tighten the jam nut.

LLL. Disconnect the links and align the provided brackets in the desired location. There is no exact location; the goal is simply to keep the sway bar clear of the tires when stowed. Mark the locations and drill with a 9/32" drill bit. Install the self-tapping screws through the bracket using a 1/2" wrench.

MMM. Re-attach the links to the lower pins and install the 1/4" Locking Pins. These may be snug against the rubber bushing, so don't be surprised if you need to use a little muscle to push them through.

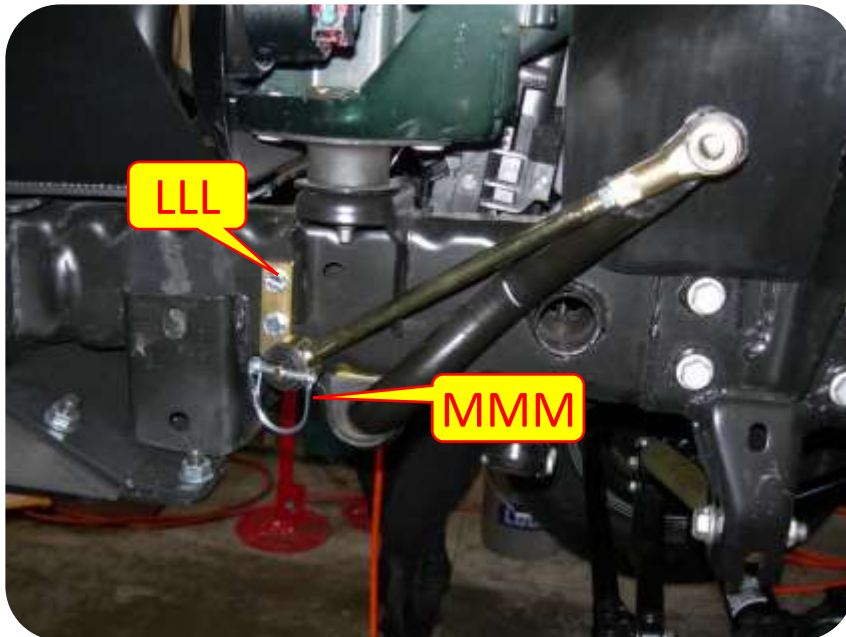

Section 3: Installation Instructions



Step 10: Finalize Installation

NNN.Adjust the caster angle and toe as needed. Once set, tighten all hardware. Finally, tighten the jam nuts on all control arms.

Note: *When lifting any vehicle, basic dynamics are changed. It is important for you to take your vehicle to a professional for alignment after installation. When doing so, make sure he is setting caster for lifted vehicle (not stock specs).*

Section 3: Installation Instructions

Step 1: Remove Stock Components

- A. Disconnect rear sway bar links. Save the lower bolt for later use.
- B. Disconnect rear brake lines. Go ahead and replace the brake lines at this time (*See Page 20*).
- C. Remove the rear track bar. Save the upper bolt for later use.
- D. Remove the shocks.
- E. Remove stock springs, and any spacers that have been used if vehicle has been previously lifted. The rubber isolator will be re-used.

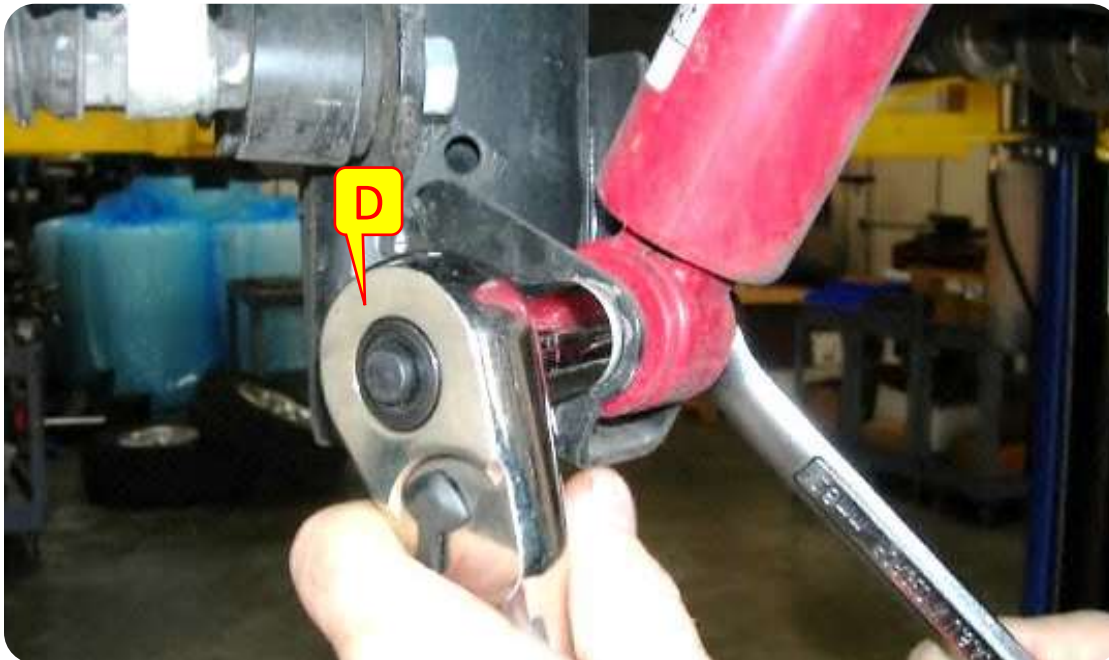

Section 3: Installation Instructions

Step 2: Install Rear Brake Lines

- F. The steps to replace the rear brake lines are essentially identical to the front. Use the M6 screw to install the L-Bracket in the stock location, and then install the Brake Line following the same steps as the front.



CAUTION!! FAILURE TO PROPERLY BLEED THE BRAKE LINES WILL CAUSE YOUR BRAKES TO BE INEFFECTIVE.

Before your vehicle is ready to drive you will need to refill the brake reservoir and bleed the air out of the brake lines. If you are not experienced with this process, or have any reservations, consult a professional. For a full write-up of the brake bleeding process for your JEEP Wrangler JK, you can also refer to <http://project-jk.com/jeep-jk-write-ups/jeep-jk-wrangler-maintenance-bleeding-your-brakes>.



Section 3: Installation Instructions

Step 3: Install Rear Control Arms

- G. Use a 21mm socket and wrench to remove the stock hardware and control arms; re-use this hardware to install MetalCloak rear control arms. The Lock Nuts should be towards the front, at the frame mount for both upper and lower control arms.
- H. The MetalCloak rear upper arm should be oriented so that the bend in the arm angles inboard to provide tire clearance.
- I. Install track bar bracket before completing the install of the lower control arm on the driver side.

		FRONT CONTROL ARMS		REAR CONTROL ARMS	
CASTOR ANGLE		UPPER	LOWER	UPPER	LOWER
FACTORY CONTROL ARMS	STOCK	22 5/8"	18 3/4"	19 3/4"	17 7/16"
METALCLOAK 2.5"/3.5" LIFT	5 DEGREES	23 1/16"	18 3/4"	20 7/16"	18 7/16"

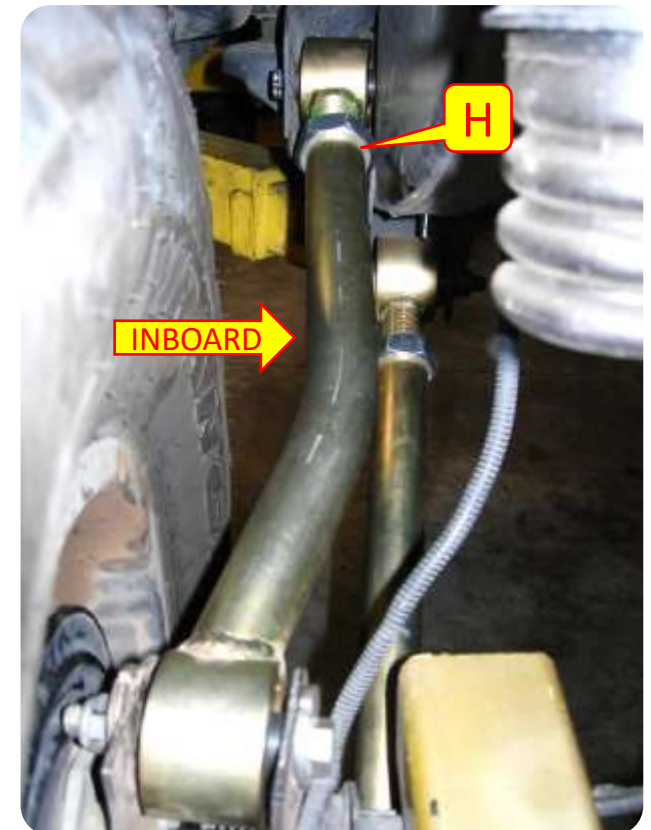

Important Note: MetalCloak ships control arms at the approximate length for 3.5" lift kits eye to eye. if you are doing a 2.5" kit, they control arms will need to be adjusted. whether 3.5" or 2.5" if you do not know the full dynamics of how to set up your control arms, please take your jeep to a professional for adjusting your caster and aligning your suspension.



Section 3: Installation Instructions

Step 4: Install MetalCloak Track Bar Bracket

- J. Slide the MetalCloak Track Bar Bracket in place as shown and re-install the stock bolt through the control arm; do not fully tighten any hardware until the Bracket is fully installed.
- K. Insert the provided Spacer in the axle bracket where the stock track bar was mounted.
- L. Install the provided M14-2x100mm" Hex Cap Screw through the stock hole with a Washer under the head of the Screw.
- M. The Screw is backed by a M14" Nylon Jam Lock Nut and Washer; install but do not fully tighten.

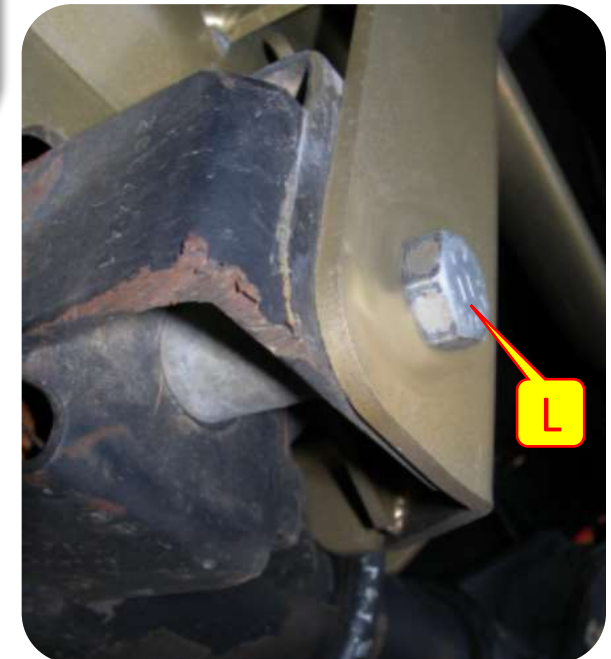
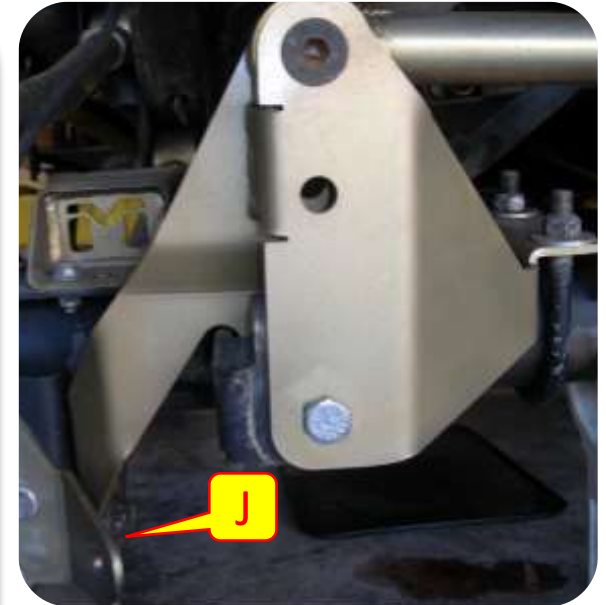

Section 3: Installation Instructions



Step 4: Install MetalCloak Track Bar Bracket

- N. Use a 3/4" Socket to install the 1/2"-20 U-bolt with the provided 1/2"-20 Flange Lock Nuts. You can snug all the Bracket hardware at this time, but do not fully tighten.



Step 5: Install MetalCloak Track Bar

- O. Pre-set the length of the MetalCloak Track Bar to 40-1/8" eye-to-eye. This length can be adjusted for your specific build.
- P. Install the MetalCloak Track Bar using the stock hardware. On the bottom the BOLT HEAD should face REARWARD, and on the upper mount the NUT should be to the rear. Tighten all hardware.

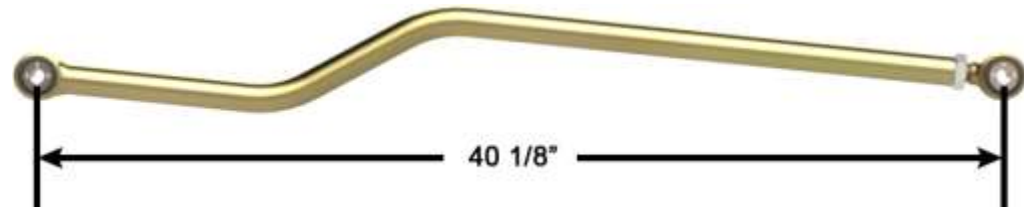

Section 3: Installation Instructions

Step 6: Install Rear Coils

- Q. If the axle does not “droop” enough to allow the coil to be put in place a coil compressor can be used to compress the coil to allow fitment.
- R. Place the Rear Coil Cup on to of the Rear Dual Rate Coil.
- S. Install Rear Dual Rate Coils with the tightly wound coils oriented upward.
- T. Slip the bottom of the coil onto the coil base on the axle.



Section 3: Installation Instructions

Step 7: Install Rear Shocks

Note: The following steps are optional; if you do not intend to trim the Lower Stock Shock Mount Bracket skip to Step 2.

- U. Mark the side of the Lower Stock Shock Mount Bracket **3-7/8"** from the bottom of the axle.
- V. Mark the rear of the Lower Stock Shock Mount Bracket **4-3/4"** from the top of the bracket.
- W. Use a Cut-off Disc and Grinder to trim the Stock Shock Mount Bracket, including any protruding portion above the marked locations. Blend the transition as shown and paint exposed metal.

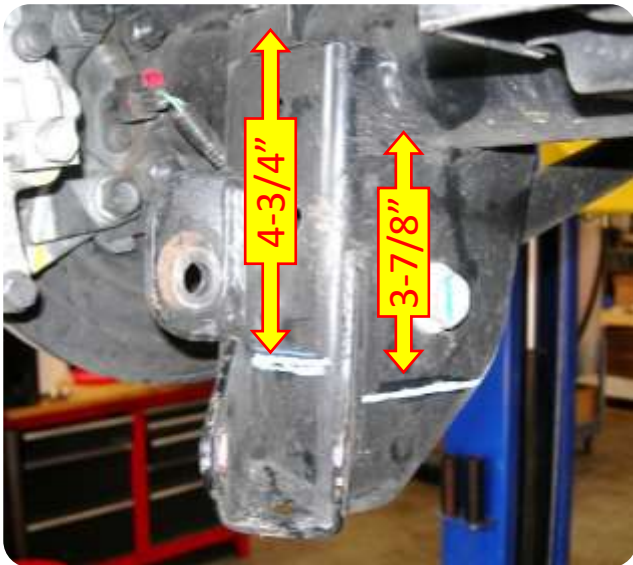

Section 3: Installation Instructions

Step 7: Install Rear Shocks

- X. Locate the MetalCloak Lower Shock Mount Bracket (Bracket is symmetrical and can be reversed for Driver and Passenger Side) using the stock holes. The lower hole of the “figure 8” opening of the Shock Mount Bracket aligns with the stock sway bar link hole as shown.
- Y. Mark the upper hole on the Shock Mount Bracket to be drilled.
- Z. Remove Shock Mount Bracket and drill marked hole with a 7/16” Drill. The frame is made from a very hard steel, and we recommend drilling a 1/4” (or similar) pilot hole.
- AA. Install the 3/8”-16 Flange Hex Head Screws and Nuts using a 9/16” Socket and Wrench.
- BB. Reinstall the stock sway bar link bolt (bolt only). From the inside out.

Important Note: Depending on your suspension setup, you may need to leave the sway bar links disconnected until after the shock installation.

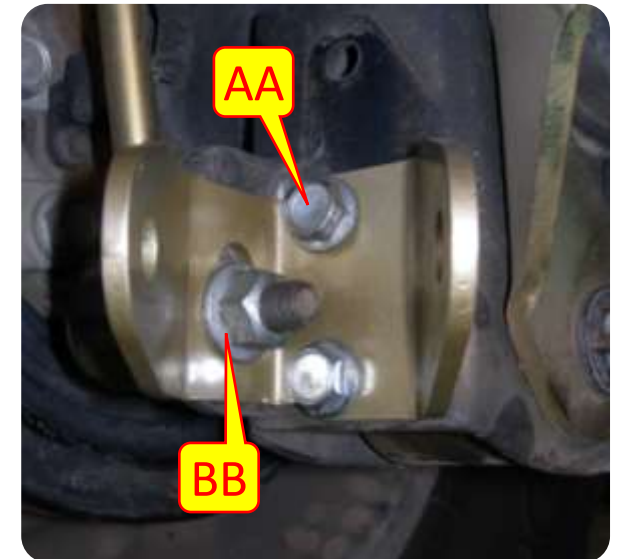
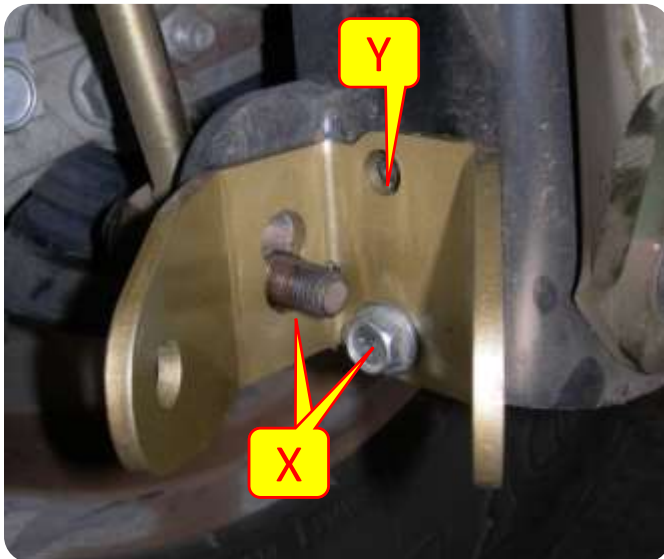

Section 3: Installation Instructions

Step 7: Install Rear Shocks

- CC. Install the Bar Pin Eliminator in the 6-Pak Shock Rod-End. Feed the male piece through the Rod-End and into the female piece.
- DD. Use a 17mm Socket, and the provided replacement M10 Screws and Washers, to install the Bar Pin Eliminator in the upper stock location, oriented so that the 6-Pak Rod End is offset INBOARD.

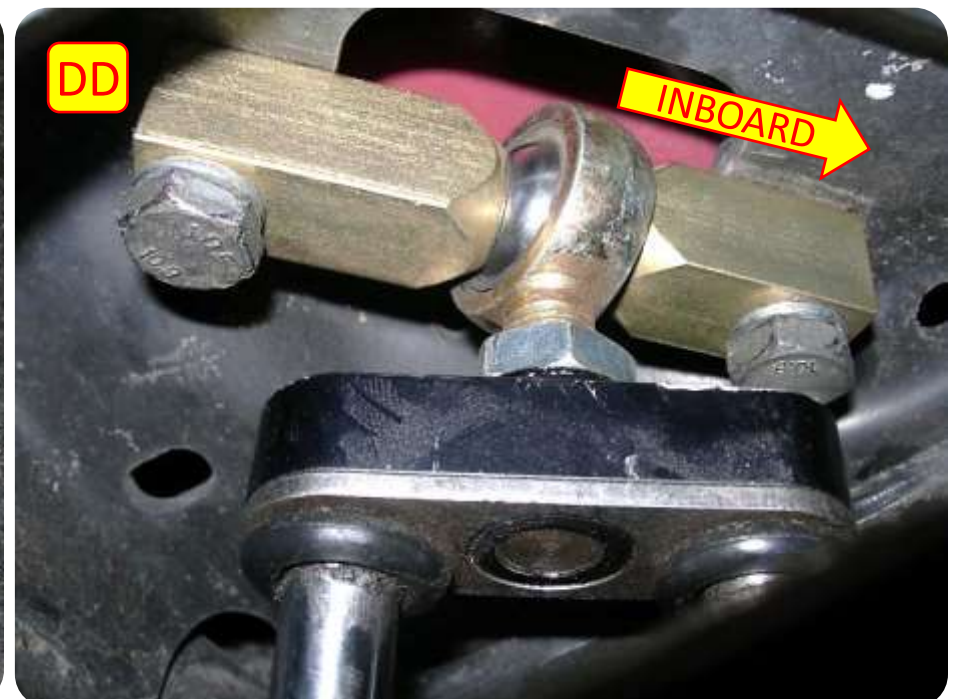

Section 3: Installation Instructions

Step 7: Install Rear Shocks

- EE. Use the provided 1/2"-13 x 2.5" Hex Head Screw, Washer, Hex Flange Nut and Spacers to install the lower Rod End (*bushing side*) in the Shock Mount Bracket. The Washer goes under the head of the Screw, and the Flange Nut goes directly against the bracket.
- FF. The 6-Pak Shock Reservoir Tubes (RED) should be oriented INBOARD. The body of the 6-Pak Shock should be oriented such that the clearance between the Stock Sway Bar and the 6-Pak Shock Body is the same as the clearance between the Track Bar Bracket and the 6-Pak Shock Body. In other words, center the Reservoir Tubes the Track Bar Bracket and Stock Sway Bar.

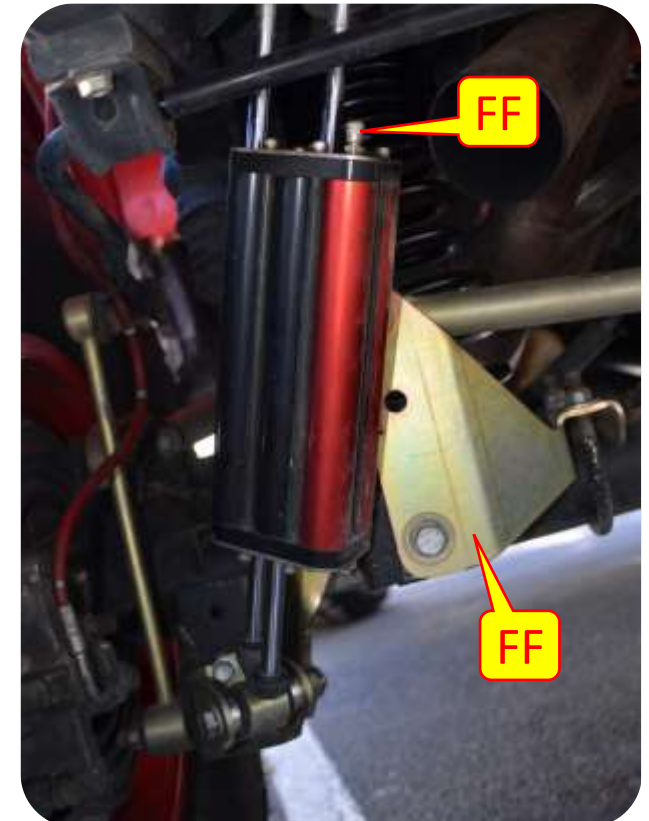

Section 3: Installation Instructions

Step 8: Sway Bar Drop (Option 1 - 7026)

- GG. Disconnect the sway bar end links at the axle
- HH. Remove the sway bar from the JK so that it no longer sits above the stock exhaust.
- II. Re-use the stock hardware to screw the drop bracket to the frame in the stock location. The bracket should be roughly vertical.
- JJ. Using the provided hardware use a 14mm or 9/16" hex socket or wrench to bolt the sway bar to the bottom of the drop bracket .
- KK. Re-attach the stock sway bar links.



Section 3: Installation Instructions

Step 8: Install Rear Sway Bar Drop Spacer (Option 2 – 7027)

LL. If you intend to replace your sway bar links with longer links, disconnect links on both ends.

MM. Remove stock hardware from sway bar mounts.

NN. Slide the sway bar to the rear or set aside.

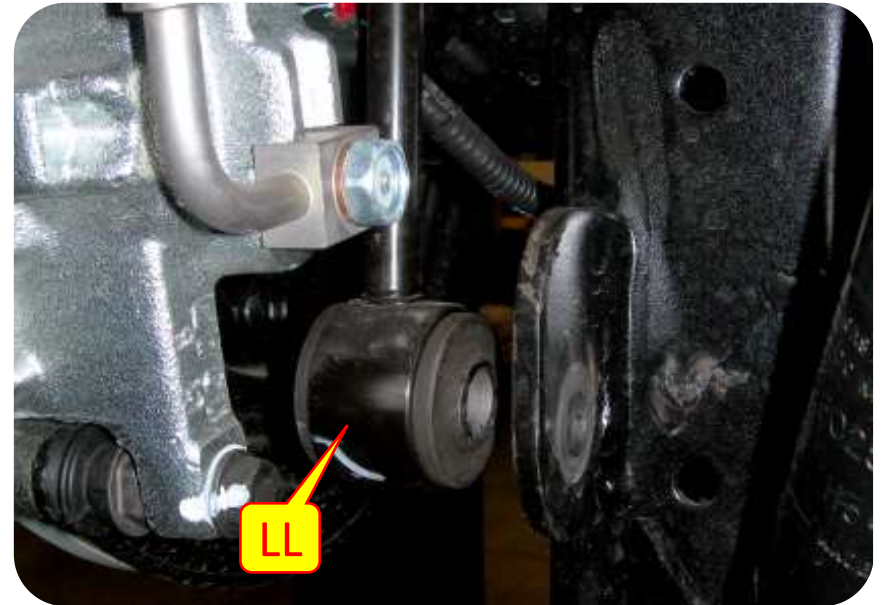

Section 3: Installation Instructions

Step 8: Install Rear Sway Bar Drop Spacer (Option 2 – 7027)

OO. Screw the provided M10 Screws through the drop spacer into the frame in the stock location. The tapped holes sit to the rear of the counter board holes.

PP. Use the provided Flange Bolts hardware use a 14mm or 9/16" hex socket or wrench to bolt the sway bar to the spacer.

QQ. Attach (or re-attach) extended Sway Bar Links.

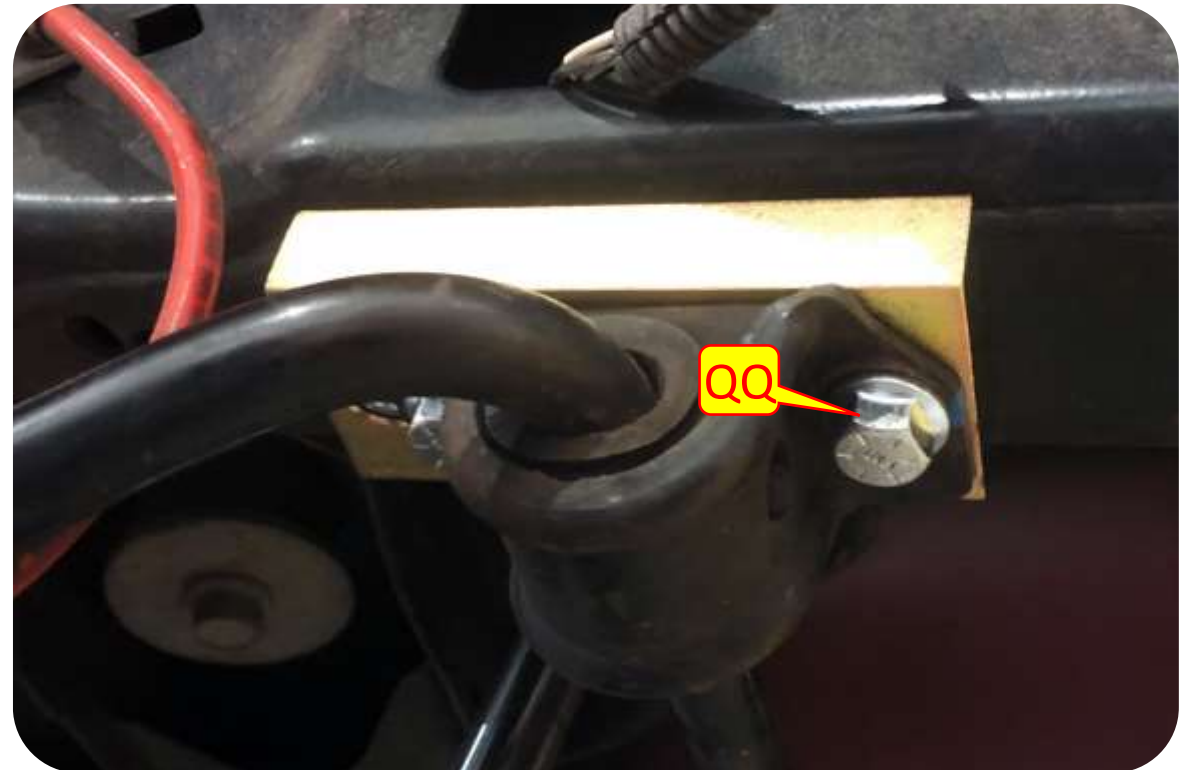
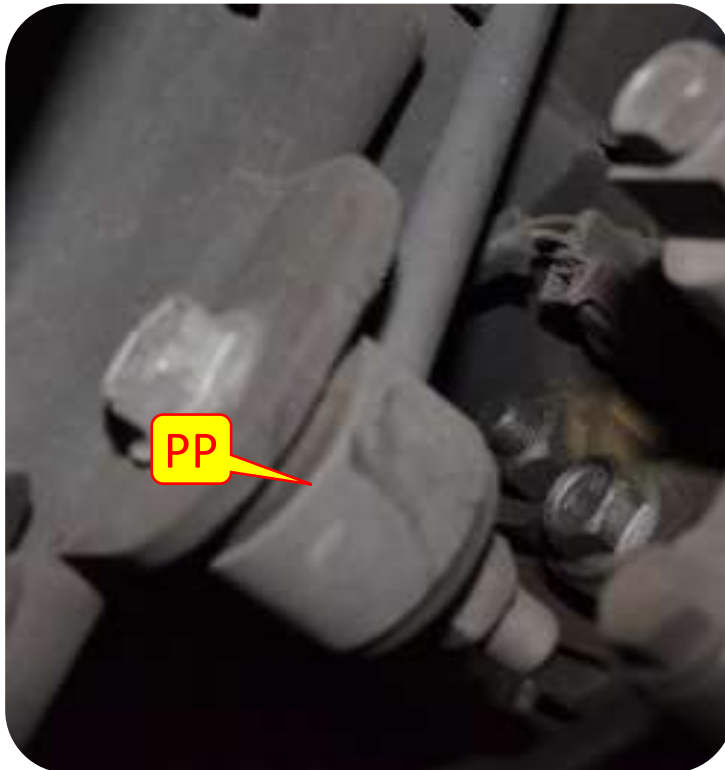
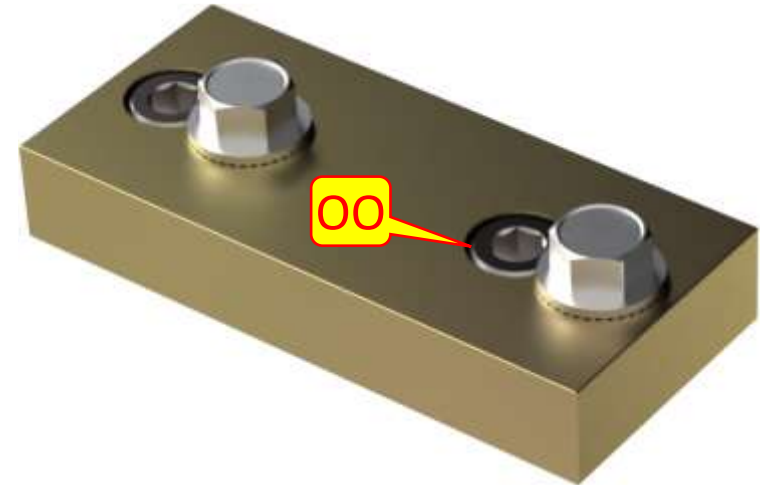

Section 3: Installation Instructions

Step 8: Install Rear Sway Bar Drop Spacer (Option 2 – 7027)

RR. Using the factory hardware install the bottom of the MetalCloak extended sway bar links.

SS. Using the factory hardware install the top of the MetalCloak extended sway bar links.

TT. Torque upper and lower bolts to 75lbs.

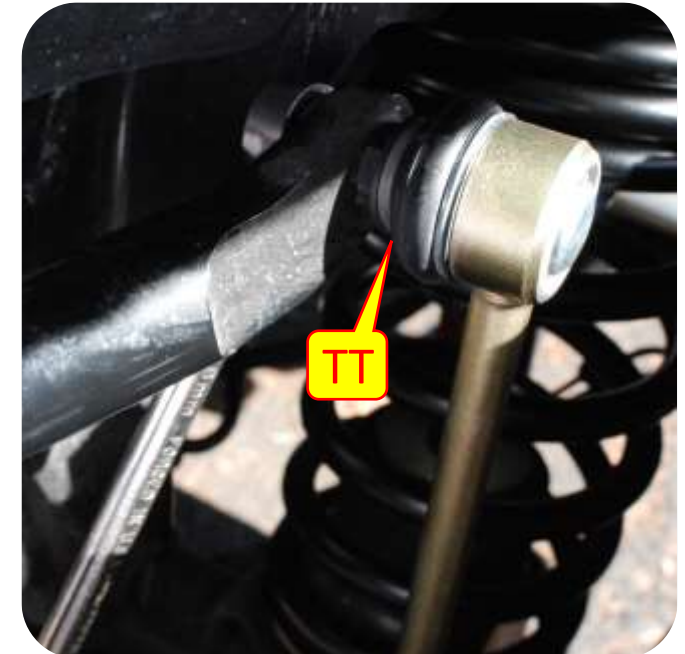
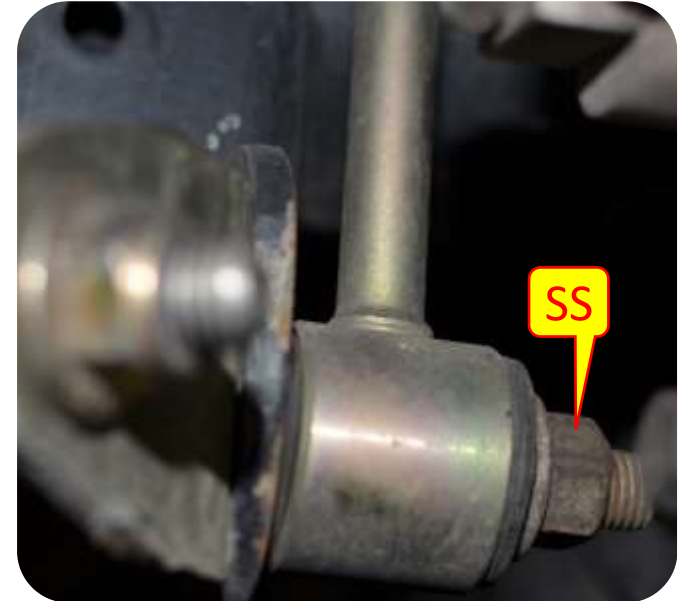
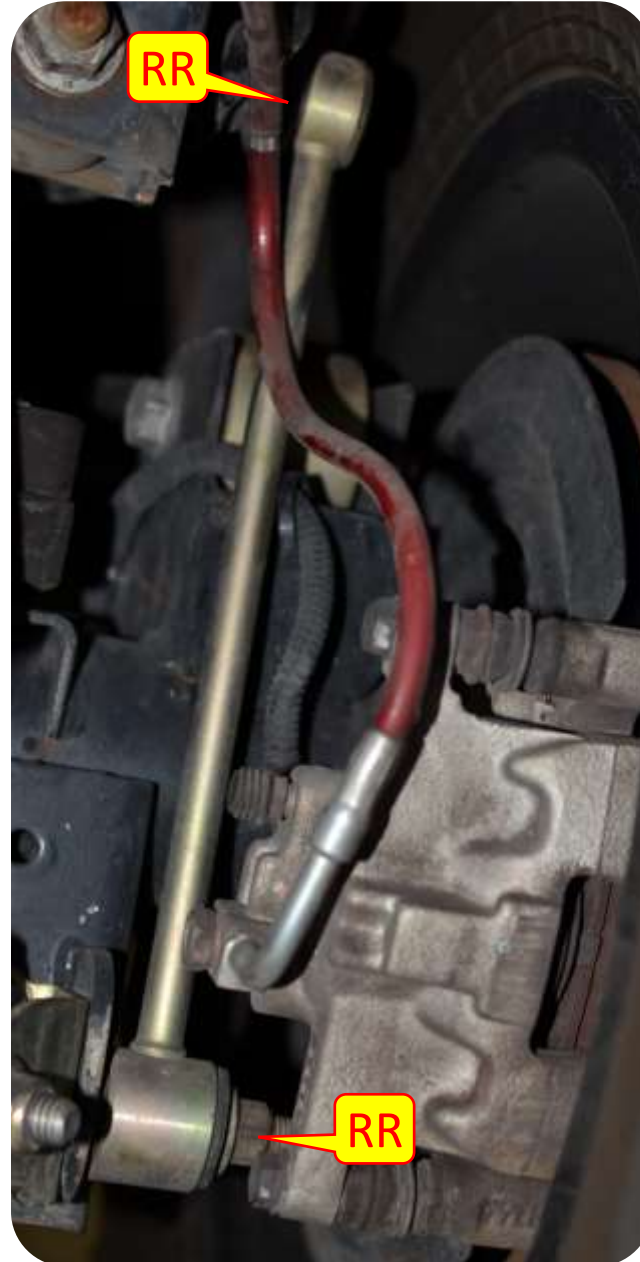

Section 3: Installation Instructions

Step 9: Install Rear Bump Stops

UU. Driver Side Bump Stop Holes.

VV. Passenger Side Bump Stop Holes.

WW. Diagram showing the two sides of the Bump Stops.

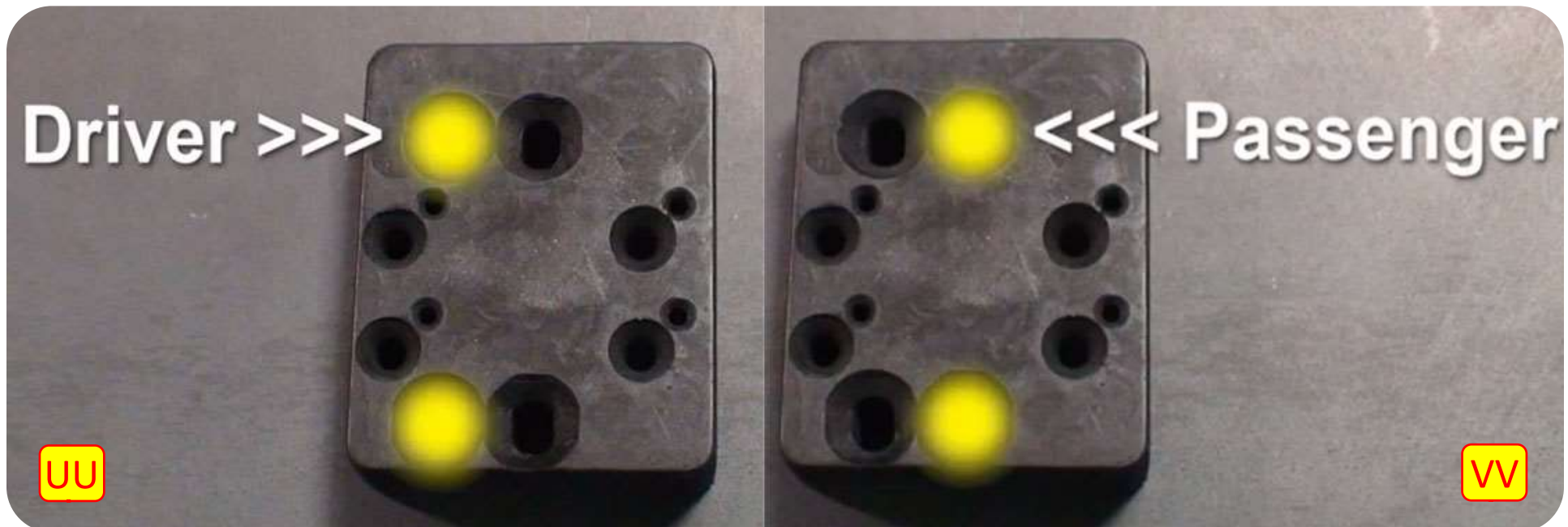

Section 3: Installation Instructions

Step 9: Install Rear Bump Stops

- XX. Install first bump stop puck (Side A) using the correct holes (shown in step A and B) using the 5/16 bolt with the matching nut and washer.
- YY. Install next puck (Side B) using the 1 3/4" woodscrews.
- ZZ. Continue until desired bump stop height (Side A/Side B/ Side A/Side B).



Section 3: Installation Instructions



Step 10: Bleed Brake Lines

Important Note: *Before driving bleed brake lines.*

