



PRODUCT: **Bronco 2-Door Overline Rocker Rails**

REV: A | 01-25-2024 | II-B0201

READ INSTRUCTIONS IN FULL BEFORE INSTALLATION.

QUESTIONS? CALL 916-631-8071 M-F 7:00 AM – 5:00 PM PST

The MetalCloak experience includes the ease of installation of our products. We design for most contingencies, but installation may be different based on different Bronco condition, configuration and/or year.

We are continually trying to improve our products and instructions – please help us by providing feedback and pictures if you find any part of the instructions that do not match your Bronco or are not easily understandable.

If you have any difficulties at all, please give us a call. Thank you and enjoy your MetalCloak Products!

IMPORTANT NOTE: We use Stainless Steel Hardware where possible. Therefore, a tube of Silver Anti-seize is provided and should be used on all bolts—only a small amount is needed.

WARRANTY INFORMATION: This article is sold without warranty expressed or implied. No warranty or representation is made as to this products ability to protect the user from injury or death. The user assumes that risk. The effectiveness, warranty and longevity of this equipment are directly related to the manner in which it is INSTALLED, USED and/or MAINTAINED. THE USER ASSUMES ALL RISK. By purchasing this product and opening the packaging, purchasers expressly acknowledge, understand and agree that they take, select and purchase these MetalCloak products from Armored Works, LLC, its affiliates and distributors and agents as is and with all faults. The entire risk as to the quality and performance of these MetalCloak products is with the purchaser. Working on your vehicle can be a dangerous activity. If you are unsure of what you are doing, please leave mechanical or safety critical work to a skilled mechanic. We take no responsibility for the incorrect use and/or installation of MetalCloak products.

Section 1: Tools & Notes on Installation



Tools Required:



Socket & Ratchet Wrench

10MM Socket
17MM Socket

13MM Socket
9/16" Socket



9/16" Box Wrench

7/32" Allen Wrench



7/16" Drill Bit

Center Punch



HOW TO USE THIS GUIDE: The installation guide contains ALL steps for installation. Please read and follow the instructions in order of each page top to bottom and left to right.

Model: Instructions may apply to multiple Bronco models but are labeled separately where appropriate.

Options: Because of the number of component options we offer, these instructions may contain steps that will not match your particular configuration. You can skip these steps.

Images: Pictures are provided, and parts are labeled throughout the instructions. Each text box contains guidance based on the pictures next to it. The text will refer to alphabetical labels (A, B, etc.) found in the images.

Installation Notes: Terms may be used in the body of the instructions that you may not be familiar with, if you have any questions feel free to contact us at the number below, or email techhelp@metalcloak.com

QUESTIONS: Any questions or comments about the instructions? Call us at 916-631-8071 M-F 7:00 AM – 5:00 PM PST.

Section 2: Product Components

ITEM	PART NUMBER/DESCRIPTION	QTY.
1	WM-7540 WELDMENT, OVERLINE ROCKER RAIL, BRONCO, 2 DOOR	1
2	WM-7540-P WELDMENT, OVERLINE ROCKER RAIL, BRONCO, 2 DOOR	1
HARDWARE		
3	FM-10213 HHCS, M10-1.5 X 40L STL C10.9 ZINC, FULL THREAD	8
4	FS-06004 WASHER, 0.41ID X 0.81OD X 0.05TH SS 18-8	18
5	FS-06031 HHCS, 0.38-16 X 1.0L STL G5 ZINC	10
6	FS-06073 SFHCS, 0.38-16 X 0.75L SS 18-8 PLAIN	2
7	FS-06196 SFHCS, 0.38-16 X 4.5L SS 18-8 PLAIN	2
8	FS-06210 NYLOCK FLANGE NUT, 0.38-16 X 0.41H STL GF ZINC	12

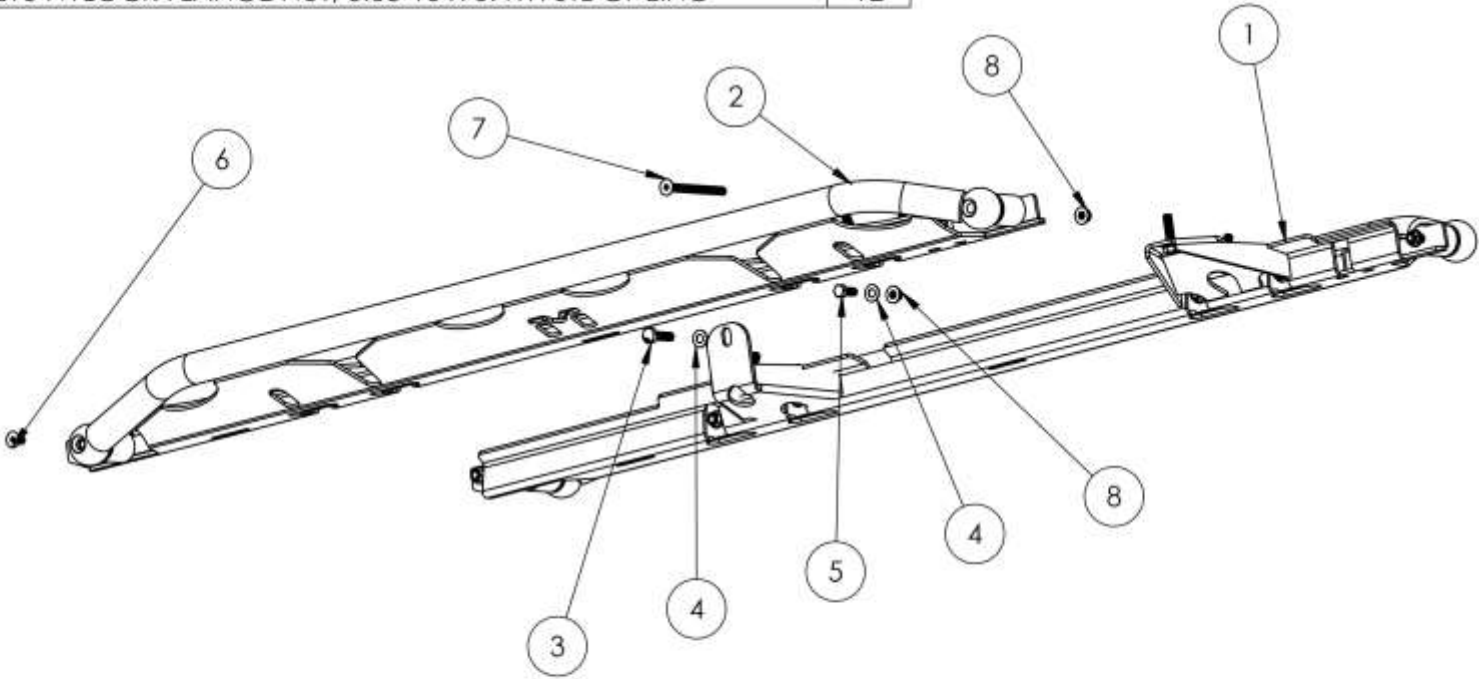

THE INFORMATION CONTAINED ON THIS DRAWING IS THE EXCLUSIVE PROPERTY OF ARMORED WORKS, LLC. UNAUTHORIZED REPRODUCTION IS PROHIBITED.

DO NOT SCALE DRAWING

PART NUMBER/DESCRIPTION
B0201 OVERLINE ROCKER STEP, BRONCO, 2 DOOR



Metal Cloak
A DIVISION OF ARMORED WORKS, LLC

Section 3: Installation Instructions

Step 1: Preparation for Rocker Installation

- A. Remove the factory rocker using a 13mm and 10mm socket.
- B. Remove the lower front fender bolt (along pinch weld, closest to front tire) using a 10mm socket.
- C. Drill out the front fender nut using a 7/16" drill bit.
- D. Lift the MetalCloak rocker into place with jack until it is fully seated against the bronco and align the front ball to the hole that was just drilled out. Install the long 3/8" flathead bolt through the ball and drilled hole to locate the rocker.



Section 3: Installation Instructions

Step 2: Bronco Overline Rocker Installation

- E. Loosely install the rocker to factory nuts in the bottom of the bronco body.
- F. Using a sharpie mark the rear rocker hole along the pinch.
- G. Remove the bolts and rocker from the bronco in preparation for drilling.
- H. Center punch and drill marked rear hole using a 7/16" drill bit. Use the 7/16" bit to drill out the remaining factory holes in the pinch weld. MetalCloak also recommends painting any exposed metal to prevent rust.

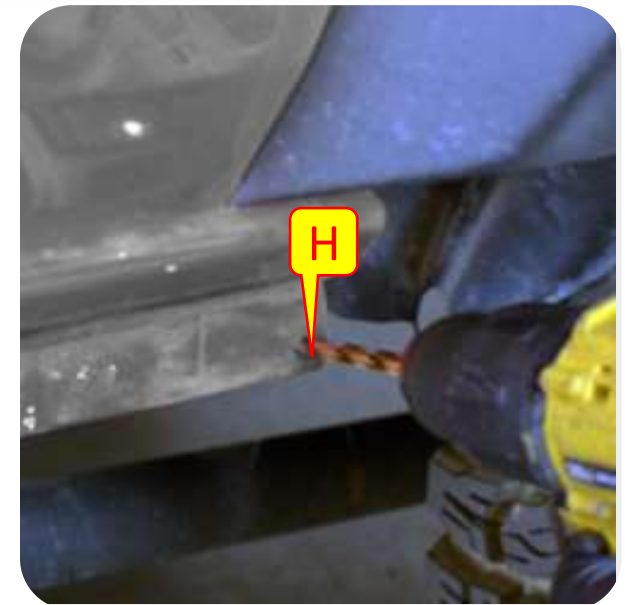

Section 3: Installation Instructions

Step 2: Bronco Overline Rocker Installation

- I. Lift rocker back into place and using a 17mm socket loosely reinstall the rocker using the provided bolts and washers and nuts in the bottom of the bronco body.
- J. Using a 9/16 socket and wrench install the provided bolts, washers and nuts into the drilled-out holes along the pinch weld.
- K. Using a 7/32" allen wrench install the provided .75" long flathead screw into the rear ball. Install the 4.5" flathead screw through the front ball, rocker, and pinch weld and thread in to the supplied nylock nut. Tighten using 7/32" allen wrench and 9/16" wrench.
- L. Once all hardware is installed; tighten all hardware.

