



PRODUCT: **Bronco SportGate Tire Carrier**

REV: A | 09-06-2023 | II-B0250

READ INSTRUCTIONS IN FULL BEFORE INSTALLATION.

QUESTIONS? CALL 916-631-8071 M-F 7:00 AM – 5:00 PM PST

The MetalCloak experience includes the ease of installation of our products. We design for most contingencies, but installation may be different based on different Jeep condition, configuration and/or year.

We are continually trying to improve our products and instructions – please help us by providing feedback and pictures if you find any part of the instructions that do not match your particular Jeep or are not easily understandable.

If you have any difficulties at all, please give us a call. Thank you and enjoy your MetalCloak Products!

IMPORTANT NOTE: We use Stainless Steel Hardware where possible. Therefore, a tube of Silver Anti-seize is provided and should be used on all bolts—only a small amount is needed.

WARRANTY INFORMATION: This article is sold without warranty expressed or implied. No warranty or representation is made as to this products ability to protect the user from injury or death. The user assumes that risk. The effectiveness, warranty and longevity of this equipment are directly related to the manner in which it is INSTALLED, USED and/or MAINTAINED. THE USER ASSUMES ALL RISK. By purchasing this product and opening the packaging, purchasers expressly acknowledge, understand and agree that they take, select and purchase these MetalCloak products from Armored Works, LLC, its affiliates and distributors and agents as is and with all faults. The entire risk as to the quality and performance of these MetalCloak products is with the purchaser. Working on your vehicle can be a dangerous activity. If you are unsure of what you are doing, please leave mechanical or safety critical work to a skilled mechanic. We take no responsibility for the incorrect use and/or installation of MetalCloak products.

Section 1: Tools & Notes on Installation



Tools Required:



Socket & Ratchet Wrench

14MM Socket
9/16" Socket
1/4" Socket



9/16" Box Wrench

T20 Torx T30 Torx
T40 Torx T45 Torx



Phillips Head Screwdriver
Flat Head Screwdriver

7/32" Allen Wrench or Socket



Tape

HOW TO USE THIS GUIDE: The installation guide contains ALL steps for installation. Please read and follow the instructions in order of each page top to bottom and left to right.

Model: Instructions may apply to multiple Bronco models but are labeled separately where appropriate.

Options: Because of the number of component options we offer, these instructions may contain steps that will not match your particular configuration. You can skip these steps.

Images: Pictures are provided, and parts are labeled throughout the instructions. Each text box contains guidance based on the pictures next to it. The text will refer to alphabetical labels (A, B, etc.) found in the images.

Installation Notes: Terms may be used in the body of the instructions that you may not be familiar with, if you have any questions feel free to contact us at the number below, or email techhelp@metalcloak.com

QUESTIONS: Any questions or comments about the instructions? Call us at 916-631-8071 M-F 7:00 AM – 5:00 PM PST.

Section 2: Product Components

DC-0001 Rev B

SHEET 1 OF 1

ITEM	PART NUMBER/DESCRIPTION	QTY.
1	CB-0117 BRAKE LIGHT MOUNT, SPORTGATE, BRONCO	1
2	WM-8550 WELDMENT, SPORTGATE, BRONCO	1
E HK-B0252		
3	FM-08058 WASHER, 8.4ID X 15OD X 1.6TH STL ZINC	12
4	FM-08168 SBHCS, TORX, M8-1.25 X 25L STL C8.8 ZINC	8
5	FM-08271 SBHCS, TORX, M8-1.25 X 50L STL C8.8 ZINC	4
6	FS-06001-BZ SBHCS, 0.38-16 X 0.75L STL G5 BLACK ZINC	8
7	FS-06053 SERRATED FLANGE LOCK NUT, 0.38-16 X 0.34H STL GF ZINC	4

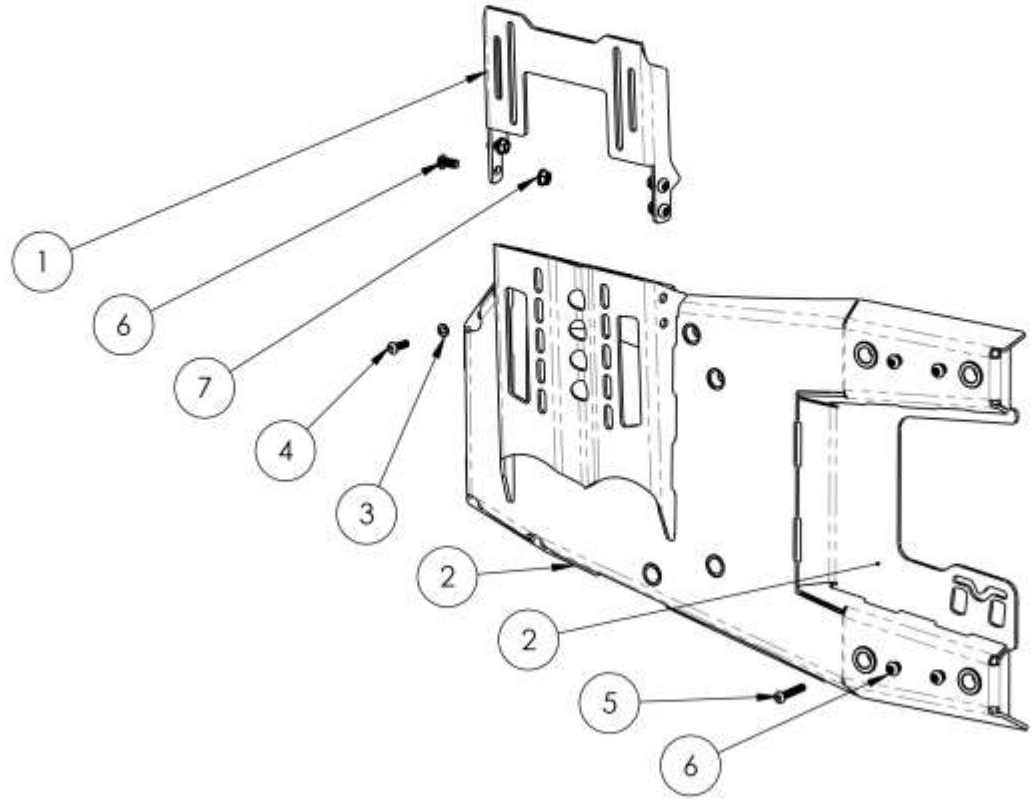

D

C

B

A

THE INFORMATION CONTAINED ON THIS DRAWING IS THE EXCLUSIVE PROPERTY OF ARMORED WORKS, LLC. UNAUTHORIZED REPRODUCTION IS PROHIBITED.

DO NOT SCALE DRAWING

PART NUMBER/DESCRIPTION **B0252 SPORTGATE, BRONCO**



A DIVISION OF ARMORED WORKS, LLC

Section 2: Product Components

ITEM	PART NUMBER/DESCRIPTION	QTY.
1	CB-0119 NUT PLATE, SPORTGATE, BRONCO	2
2	CB-0120 CAMERA MOUNT, SPORTGATE, BRONCO	1
3	FM-12209 WHEEL STUD, M12-1.5 X 42L STL	3
4	FS-00179-BZ HHCS FLANGE SELF-TAP, 6-20 X 0.5L STL BLACK ZINC	2
5	FS-06053 SERRATED FLANGE LOCK NUT, 0.38-16 X 0.34H STL GF ZINC	2
6	FS-06104 HHCS SERRATED FLANGE, 0.38-16 X 0.75L STL G5 ZINC	8
7	WM-3931 WELDMENT, VERTICAL ADJUSTMENT BRACKET, JK	1
8	WM-8551 WELDMENT, HORIZONTAL ADJUSTMENT BRACKET, BRONCO	1

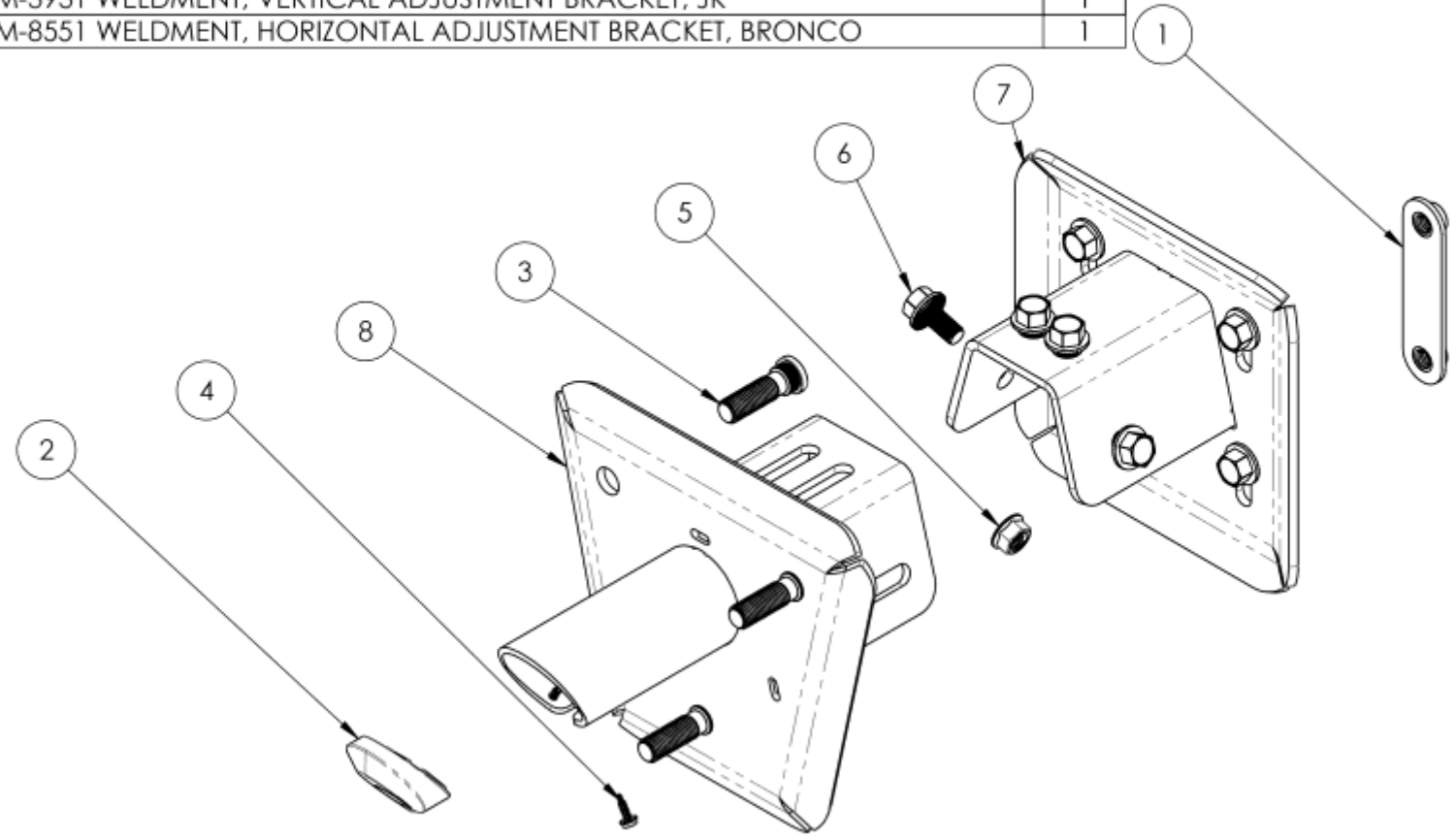

THE INFORMATION CONTAINED ON THIS DRAWING IS THE EXCLUSIVE PROPERTY OF ARMORED WORKS, LLC. UNAUTHORIZED REPRODUCTION IS PROHIBITED.
DO NOT SCALE DRAWING

Metal Cloak
 A DIVISION OF ARMORED WORKS, LLC

PART NUMBER/DESCRIPTION
 B0250 SPORTGATE TIRE MOUNT, 4.50 TO 6.20 MOUNT, BRONCO

Section 3: Installation Instructions

Step 1: Factory Tire Carrier Removal

- A. Remove the spare tire.
- B. Using a 14mm socket disconnect the factory tire carrier from the tailgate.
- C. Using a T30 torx wrench remove the bolts securing the camera mount to the factory tire carrier.
- D. Using a T30 torx wrench remove the bolts holding the third brake light to the factory tire carrier. **Save Hardware.**

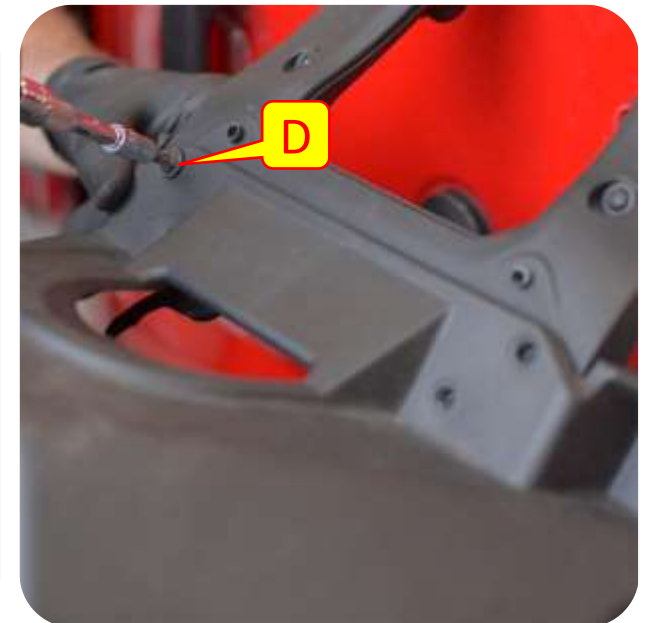
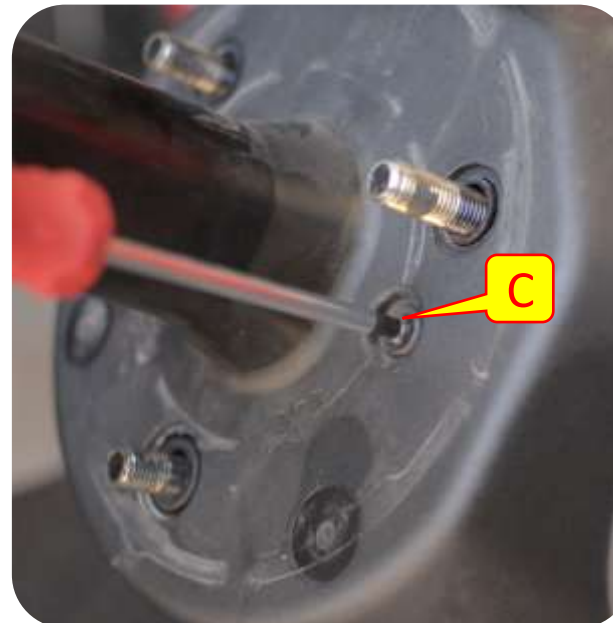

Section 3: Installation Instructions

Step 2: Back Up Camera Removal

- E. On the camera mount disconnect the wire from the back up camera.
- F. Using a T20 torx wrench remove the bracket holding the backup camera into place.
- G. Remove the back up camera from the camera mount.



Section 3: Installation Instructions

Step 3: Third Brake Light Mount and Tire Mount Install

- H. Using the provided bolts and nuts install the third brake light mount to the SportGate Tire Carrier.
- I. Using a 7/32" allen socket and 9/16" wrench tighten the light mount to the SportGate Tire Carrier.
- J. Install the vertical adjustment bracket to the SportGate in the position you would like your spare tire to sit and using a 9/16" socket and wrench tighten the provided bolts (J1) into the captive nuts in the nut plates (J2).

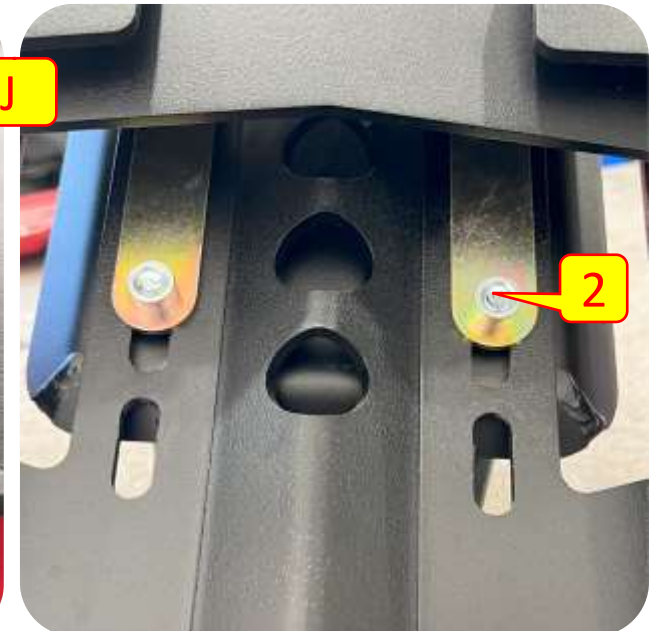
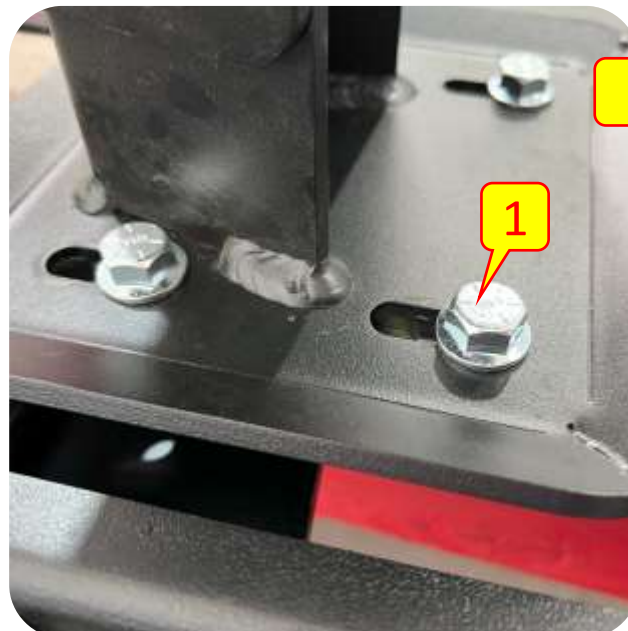
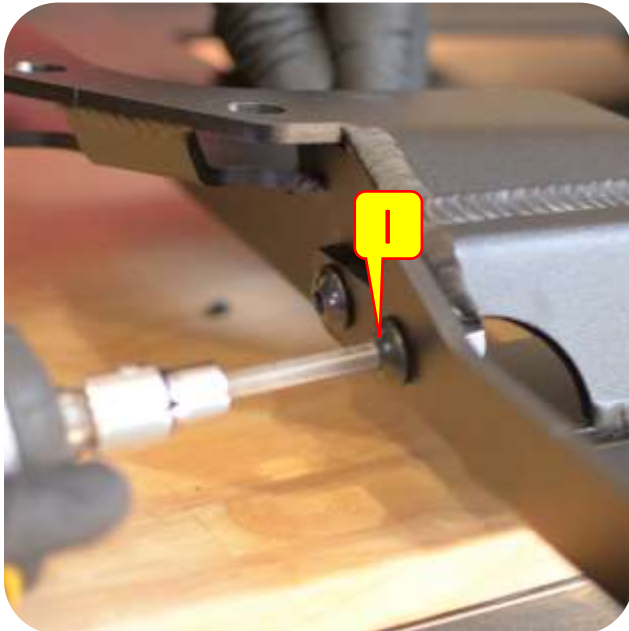
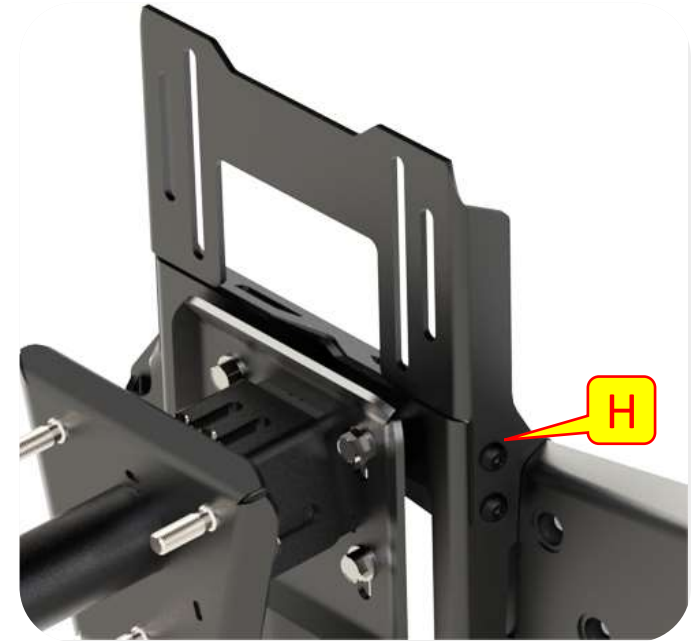

Section 3: Installation Instructions

Step 4: Press in Wheel Studs

- K. To press the wheel stud into place. Place the wheel stud into the adjustment bracket in the chosen wheelbase location.
- L. Place a long socket on the other end of the adjustment bracket. Make sure the socket has enough room for the wheel stud to be pressed in fully.
- M. Place the wheel stud and socket inside a vice (M1) and tighten the vice until the wheel stud is completely pressed in (M2). repeat process for remaining wheel studs.

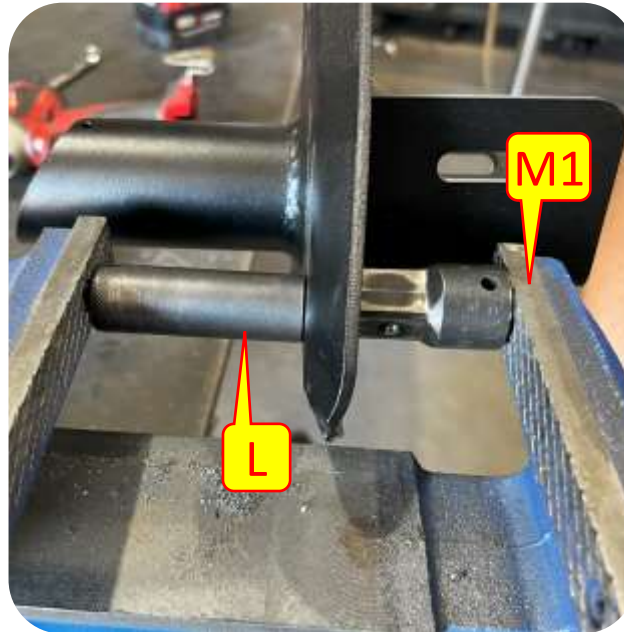

Section 3: Installation Instructions

Step 5: SportGate Tire Carrier Installation

- N. Open the tailgate and using a flat head screwdriver pop the tab on the gas strut and remove the strut on either the body side or tailgate side. You can remove the strut all together if you would prefer but is not necessary.
- O. On the passenger side of the tailgate remove the lower rubber stopper with a Philips head screwdriver.
- P. We will be disconnecting the tailgate hinge bolts. Make sure the tailgate is shut securely and using painter's tape and placing wood or cardboard under the tailgate will help keep the tailgate in place when the bolts are removed.

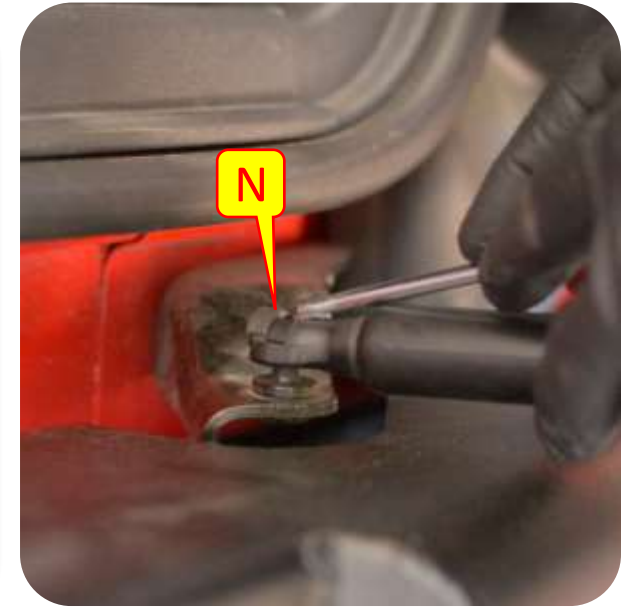

Section 3: Installation Instructions

Step 5: SportGate Tire Carrier Installation

- Q. Using a T45 torx wrench remove the four tailgate hinge bolts.
- R. Using the supplied bolts and washers install the SportGate tire carrier to the tailgate hinges loosely.
- S. Before installing the remaining bolts make sure to tuck the third brake light wiring behind the SportGate.
- T. Using the provided bolts install the SportGate to the tailgate. Once all bolts have been installed tighten all the tire carrier and hinge bolts with a T40 torx.

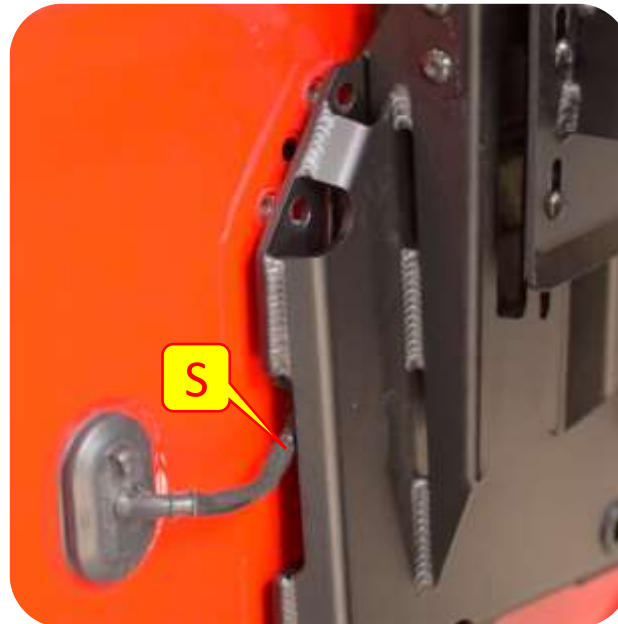
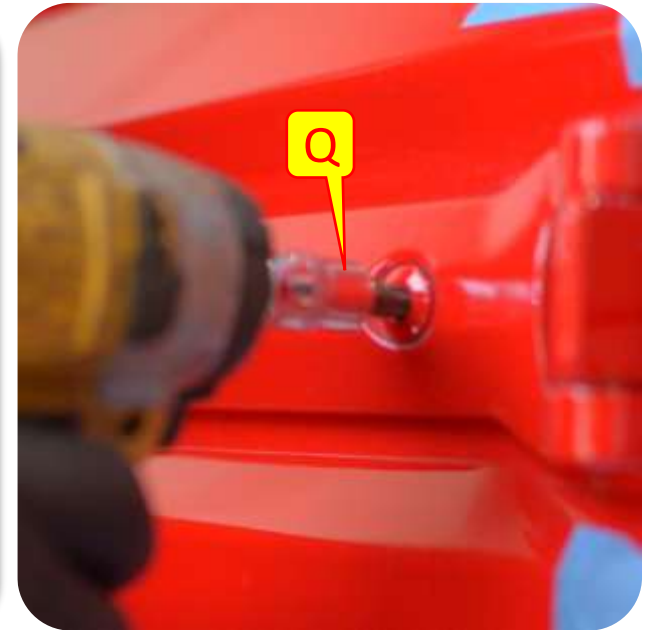

Section 3: Installation Instructions

Step 5: SportGate Tire Carrier Installation

- U. Install the third brake light to the SportGate brake light mount using the stock hardware. Tighten with a T30 torx wrench.
- V. We recommend plugging the camera back into the camera wiring and making sure the camera is installed in the correct position. The bronco may need to be in reverse before the camera activates having a second pair of hands is helpful **BE CAREFUL**. Once you know the proper orientation of the backup camera install the camera into the provided camera mount.
- W. Insert the backup camera wiring through the backspacing tire adjustment mount.

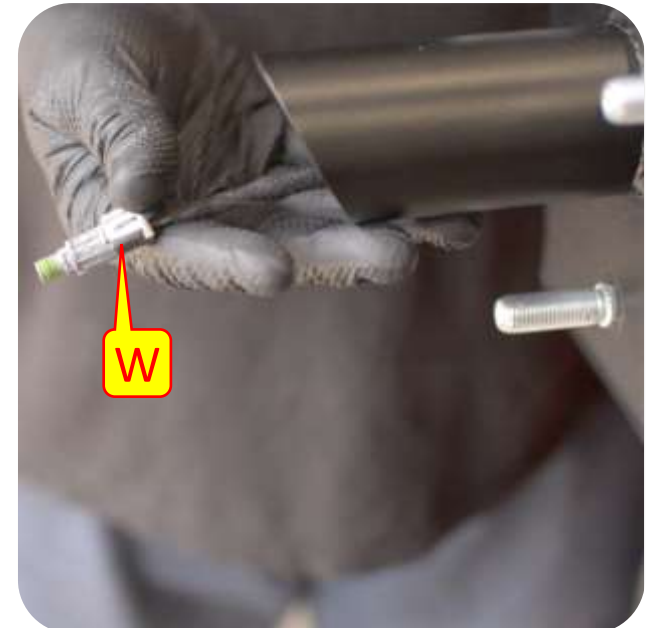

Section 3: Installation Instructions

Step 5: SportGate Tire Carrier Installation

- X. Loosely install the backspacing adjustment bracket to the tire carrier bracket using the provided hardware.
- Y. Connect the back up camera wiring to the back up camera.
- Z. Install the backup camera into the backspacing adjustment bracket and tighten the provided hardware with a 1/4" socket.
- AA. Using a 7/32" allen wrench install the provided bolts into the SportGate accessory mount bolt locations.

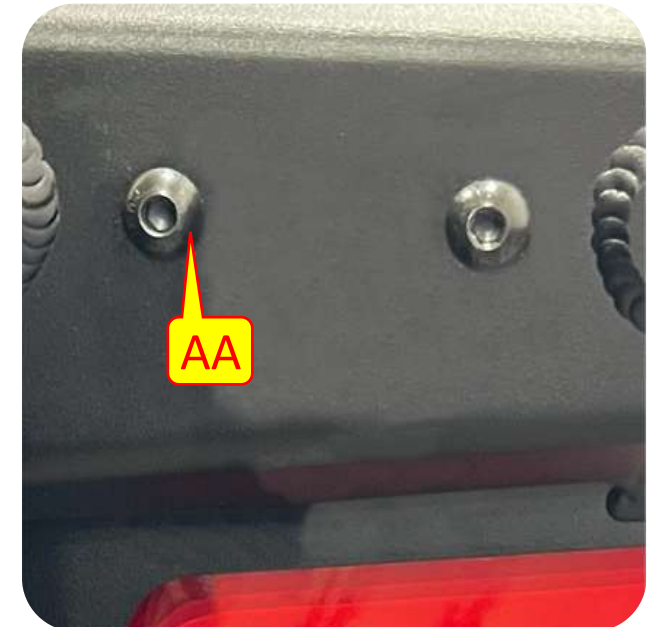
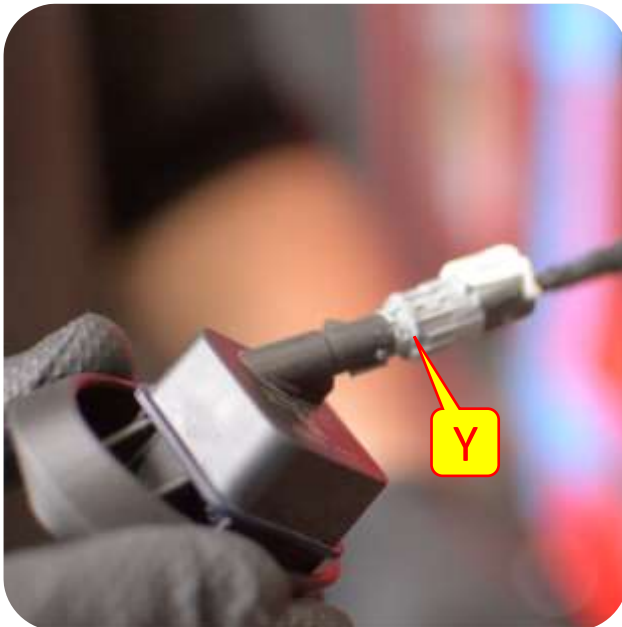
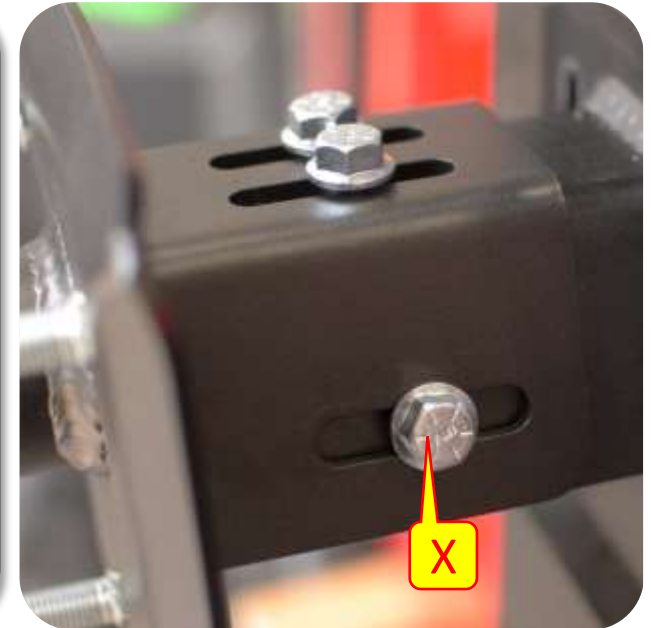

Section 3: Installation Instructions

Step 5: SportGate Tire Carrier Installation

- BB. Install the spare tire. Making sure it is snug against the SportGate to reduce tire movement.
- CC. Remove the tape to open the tailgate and tighten all hardware using a 9/16" socket while pulling the tire firmly against the tailgate.
- DD. Reconnect the tailgate gas strut

